

INSTALLATION MANUAL

# 200 SERIES



200P and 250P





**Aqua-Hot 200P and 250P Installation Manual**

Introduction & Cautions .....	4
<b>Section 1: Aqua-Hot Hydronic Heating System</b>	
Safety Instructions & Precautions .....	5
Heating System Features .....	8
<b>Section 2: Aqua-Hot Installation</b>	
Installing the Mounting Tray and Aqua-Hot.....	10
Aqua-Hot Measurement diagrams.....	11
Pressure Testing the Aqua-Hot .....	13
Installing the Expansion Tank .....	13
<b>Section 3: Hydronic Heating System</b>	
Heat Exchanger Floor Plan .....	14
Heat Exchanger Mounting Requirements .....	15
Mounting the Heat Exchangers.....	16
Heat Exchanger Location and Clearances .....	17
Optional Bay Heating .....	18
Wiring the Heat Exchanger.....	19
Plumbing the Hydronic Heating System .....	21
<b>Section 4: Domestic Water System</b>	
Domestic Water System Requirements & Plumbing .	24
<b>Section 5: Switch Panel</b>	
200P Switch Panel Location, Mounting, Wiring.....	25
250P Switch Panel Location, Mounting, Wiring.....	26
200P/250P Switch Panel Rear View.....	27

**Section 6: Fuel System**

Propane Connection.....	28
-------------------------	----

**Section 7: Exhaust System**

Exhaust System Requirements.....	29
Installing the Exhaust System.....	29

**Section 8: Electronic Controller Wiring**

Connecting the 12V DC Power.....	32
Connecting the 120V AC Power.....	33

**Section 9: Purging the System**

Purging the Hydronic Heating System .....	34
---	----

**Section 10: Initial Start-up**

Activating the Aqua-Hot.....	35
Interior Heat.....	35

**Appendices**

Appendix A: Wiring Diagram.....	36
Appendix B: Measuring Antifreeze Refractometer.....	38

**Warranty**

Warranty Information.....	39
---------------------------	----

## About the Aqua-Hot 200P and 250P

The Aqua-Hot 200P and 250P are hydronic (water based) heating systems, that provide interior heat and tank-less, continuous, hot water in one, small easy to install package.

The heating system provides moist, quiet, comfortable, interior heat. It is equipped with one thermostatically-controlled temperature zone.

The tank-less hot water system produces 90 gallons per hour (1.5 Gallons/minute) of continuous hot water.

These TribridHot™ designated systems use one or a combination of heat sources to heat FDA-approved “Generally Recognized as Safe” (GRAS) propylene glycol based anti-freeze solution in the Aqua-Hot’s boiler tank.

The 200P uses a 12 Volt-DC powered propane burner to heat the system and does not have an electric element . Use the propane burner for heating power in all circumstances.

The 250P uses a 12 Volt-DC powered propane burner as the primary heating source. The propane burner should be used for continuous hot water, and heating in cold conditions. It also has one 120 Volt-AC, 1000 Watt electric element for use when shore power is available. The Electric element is a supplemental heat source. Once the tank is up to operating temperature, the electric element may be used to maintain the operating temperature and provide light-duty hot water and interior heat. This is only available on the 250P Model. The propane burner and electric element can be used separately or together.

For continuous hot water, or for heat in colder conditions, the burner must be on.

Should additional assistance be needed, please contact the Product Application Department at 1-800-685-4298, Monday through Friday, between the hours of 7 a.m. and 4 p.m. Mountain Time.

## Caution Notes

As you read this Information, take particular note of the NOTICE, CAUTION, WARNING and DANGER symbols when they appear. This information is important for safe and efficient use of the Aqua-Hot equipment.

### NOTICE

**NOTICE** signals a situation where potential damage to the equipment could occur.

### CAUTION

**CAUTION** signals a situation where potential harm or risk of minor or moderate injury could occur if you do not follow instructions.

### WARNING

**WARNING** signals a hazardous situation where potential harm, risk of serious injury or death could result if you do not follow instructions.

### DANGER

**DANGER** signals a situation where immediate risk of serious injury or death will result if you do not follow instructions.

**NOTE** In addition, this manual may indicate an **IMPORTANT NOTE** that highlights information that is especially important.



**IMPORTANT NOTE:** Read all instructions before installing this appliance.

- Read this Installation Manual before installing or using the Aqua-Hot System to reduce the risk of injury to persons or damage to equipment.
- The product identity label contains specifications of the unit, to what standard it has been tested, and important safety notices.
- The Aqua-Hot must be installed in a compartment that is closed off from living quarters and accessible only from outdoors.
- Propylene glycol based antifreeze “Generally Recognized as Safe” by the FDA must be utilized for anti-freeze and water heating solution.
- An interlock switch prevents the Aqua-Hot heater from operating when the cover is not installed in the correct position.
- Should any additional assistance be needed, please contact the Product Application Department at 800-685-4298 or 303-651-5500.

## CAUTION

- Disconnect electric wiring to the Aqua-Hot System before welding or plasma cutting the coach to avoid damage to equipment.
- Air pressure to the tank must not exceed 20 PSI or will cause internal damage.
- The Aqua-Hot’s exhaust is HOT and must be kept away from heat sensitive material.
- Use caution when working on or near the propane gas system.
- DO NOT connect the 12 Volt-DC power to the Aqua-Hot if the vehicle requires welding.
- At maximum operating temperatures, the coolant will be very hot and scalding hot vapor or coolant may result in serious burns or injury.
- DO NOT activate the burner until the antifreeze and water heating solution has been added to the boiler tank to avoid serious damage to the heater.

## WARNING

*If this information in these instructions is not followed exactly, a fire or explosion may result causing property damage, personal injury, or death.*

- Do not store or use gasoline or other flammable vapors and liquids in the vicinity of this or any other appliance.

### WHAT TO DO IF YOU SMELL GAS

- Evacuate all persons from the vehicle.
- Shut off the gas supply at the gas container or source.
- Do not touch any electrical switch or use any phone or radio in the vehicle.

- Do not start the vehicle’s engine or electric generator.
- Contact the nearest gas supplier or qualified service technician for repairs.
- If you cannot reach a gas supplier or qualified service technician, contact the nearest fire department.
- Do not turn on the gas supply until the gas leak(s) has been repaired.
- Installation and service must be performed by a qualified installer, service agency, or gas supplier.

# NOTICE

This appliance operates on DC power.

Use only nontoxic propylene glycol based boiler antifreeze with additives generally recognized as safe ("GRAS") by the FDA.

Failure to winterize your heater, when stored in freezing temperatures, will result in serious damage to the product's domestic hot water heating system.

Air pressure applied to the tank must not exceed 20 psi. Excess pressure will result in internal damage.

For detailed information, reference the owner's manual or contact Aqua-Hot Heating Systems, Inc. at 800-685-4298.

# AVIS

Cet appareil fonctionne avec une alimentation C.C.

Utiliser uniquement un antigel de chaudière à base de propylène glycol non toxique avec des additifs généralement jugés sans danger « GJSD » (« GRAS » / generally recognized as safe) par la FDA.

Ne pas hiverner l'appareil de chauffage lorsqu'il est entreposé à des températures inférieures à 0 °C provoquera de graves dommages au système de chauffage d'eau chaude domestique du produit.

La pression d'air appliquée au réservoir ne doit pas dépasser 20 psi. Tout excès de pression provoquera des dommages internes.

Pour des informations détaillées, consulter le manuel d'utilisation et contacter Aqua-Hot Heating Systems, Inc. en composant le 800-685-4298.

# SAFETY INSTRUCTIONS

**A.** This appliance does not have a pilot. It is equipped with an ignition device, which automatically lights the burner. Do not try to light the burner by hand.

**B.** BEFORE OPERATING, smell all around the appliance area for gas. Be sure to smell next to the floor because some gas is heavier than air and will settle on the floor.

## WHAT TO DO IF YOU SMELL GAS

- Do not try to light any appliance.
- Immediately call your gas supplier from a neighbor's phone. Follow the gas supplier's instructions.
- If you cannot reach your gas supplier, call the fire department.

**C.** Use only your hand to push in or turn the gas control knob. Never use tools. If the knob will not push in or turn by hand, don't try to repair it, call a qualified service technician. Forced or attempted repair may result in a fire or explosion.

**D.** Do not use this appliance if any part has been under water. Immediately call a qualified service technician to inspect the appliance and to replace any part of the control system and any gas control which has been under water.

# CONSIGNES DE SÉCURITÉ

**A.** Cet appareil ne comporte pas de veilleuse. Il est muni d'un dispositif d'allumage qui allume automatiquement le brûleur. Ne tentez pas d'allumer le brûleur manuellement.

**B.** AVANT DE FAIRE FONCTIONNER, renifliez tout autour de l'appareil pour détecter une odeur de gaz. Renifliez près du plancher, car certains gaz sont plus lourds que l'air et peuvent s'accumuler au niveau du sol. QUE FAIRE SI VOUS SENTEZ UNE ODEUR DE GAS :

- Ne pas tenter d'allumer d'appareil.
- Ne touchez à aucun interrupteur ; ne pas vous servir des téléphones se trouvant dans le bâtiment.
- Appelez immédiatement votre fournisseur de gaz depuis un voisin. Suivez les instructions du fournisseur.
- Si vous ne pouvez rejoindre le fournisseur, appelez le service des incendies.

**C.** Ne poussez ou tournez la manette d'admission du gaz qu'à la main, ne jamais utiliser d'outil. Si la manette reste coincée, ne pas tenter de la réparer, appelez un technicien qualifié. Le fait de forcer la manette ou de la réparer peut déclencher une explosion ou un incendie.

**D.** N'utilisez pas cet appareil s'il a été plongé dans l'eau, même partiellement. Faites inspecter l'appareil par un technicien qualifié et remplacez toute partie du système de contrôle et toute commande qui ont été plongés dans l'eau.



www.aqua-hot.com

# OPERATING INSTRUCTIONS

1. STOP! Read the safety information to the left on this label.
2. This appliance is equipped with an ignition device, which automatically lights the burner. Do not try to light the burner by hand.
3. Ensure that the gas control valve is turned on. Follow "B" in the safety information to the left on this label. If you don't smell gas, go to the next step.

4. Refer to the Owner's Manual for information regarding normal operation of this heating system.

5. If the appliance will not operate, follow the instructions "To Turn Off Gas To Appliance" below on this label and refer to the Owner's Manual troubleshooting section or call the technical support department at 1-800-685-4298.

# TO TURN OFF GAS TO APPLIANCE

1. Turn off all electric power to the appliance if service is to be performed.
2. Set all interior thermostats to their lowest setting.
3. Turn the gas control knob located on the heater's propane inlet port clockwise to the "OFF" position.

# INSTRUCTIONS DE MISE EN MARCHÉ

1. ARRÊTEZ! Lisez les instructions de sécurité sur la portion à gauche de cette étiquette.

2. Cet appareil est muni d'un dispositif d'allumage qui allume automatiquement le brûleur. Ne tentez pas d'allumer le brûleur manuellement.

3. Assurez-vous que la soupape de contrôle de gaz est bien ouverte. Passez à l'étape B des instructions de sécurité sur la portion à gauche de cette étiquette. S'il n'y a pas d'odeur de gaz, passez à l'étape suivante.



4. Référez au Manuel du propriétaire pour des informations au sujet du fonctionnement normal de ce système de chauffage.

5. Si l'appareil ne fonctionne pas, veuillez suivre les instructions « Pour couper le gaz vers l'appareil » ci-dessous sur cette étiquette et référez à la section Dépannage du Manuel du propriétaire ou appelez le service de soutien technique au 1.800.685.4298.

# COMMENT COUPER L'ADMISSION DE GAZ DE L'APPAREIL

1. Coupez l'alimentation électrique de l'appareil s'il faut procéder à l'entretien.
2. Réglez tous les thermostats intérieurs à leur réglage le plus bas.
3. Tournez le bouton de contrôle du gaz, situé sur le port d'entrée de propane du chauffe-eau, vers la droite à la position « OFF » (Arrêt).



<h1 style="text-align: center;">NOTICE</h1>	<p>This appliance operates on both AC and DC power.</p> <p>Use only nontoxic propylene glycol based boiler antifreeze with additives generally recognized as safe ("GRAS") by the FDA.</p> <p>Failure to winterize your heater, when stored in freezing temperatures, will result in serious damage to the product's domestic hot water heating system.</p> <p>Air pressure applied to the tank must not exceed 20 psi. Excess pressure will result in internal damage.</p> <p>For detailed information, reference the owner's manual or contact Aqua-Hot Heating Systems, Inc. at 800-685-4298.</p>	<h1 style="text-align: center;">SAFETY INSTRUCTIONS</h1>	<p>A. This appliance does not have a pilot. It is equipped with an ignition device, which automatically lights the burner. Do not try to light the burner by hand.</p> <p>B. BEFORE OPERATING, smell all around the appliance area for gas. Be sure to smell next to the floor because some gas is heavier than air and will settle on the floor.</p> <p><b>WHAT TO DO IF YOU SMELL GAS</b></p> <ul style="list-style-type: none"> <li>-Do not try to light any appliance.</li> <li>-Do not touch any electric switch; do not use any phone in your building.</li> <li>-Immediately call your gas supplier from a neighbor's phone. Follow the gas supplier's instructions.</li> <li>-If you cannot reach your gas supplier, call the fire department.</li> </ul> <p>C. Use only your hand to push in or turn the gas control knob. Never use tools. If the knob will not push in or turn by hand, don't try to repair it, call a qualified service technician. Forced or attempted repair may result in a fire or explosion.</p> <p>D. Do not use this appliance if any part has been under water. Immediately call a qualified service technician to inspect the appliance and to replace any part of the control system and any gas control which has been under water.</p>	<h1 style="text-align: center;">OPERATING INSTRUCTIONS</h1>	<ol style="list-style-type: none"> <li>1. STOP! Read the safety information to the left on this label.</li> <li>2. This appliance is equipped with an ignition device, which automatically lights the burner. Do not try to light the burner by hand.</li> <li>3. Ensure that the gas control valve is turned on. Follow "B" in the safety information to the left on this label. If you don't smell gas, go to the next step.</li> <li>4. Refer to the Owner's Manual for information regarding normal operation of this heating system.</li> <li>5. If the appliance will not operate, follow the instructions "To Turn Off Gas To Appliance" below on this label and refer to the Owner's Manual troubleshooting section or call the technical support department at 1-800-685-4298.</li> </ol>
<h1 style="text-align: center;">AVIS</h1>	<h1 style="text-align: center;">CONSIGNES DE SÉCURITÉ</h1>	<h1 style="text-align: center;">TO TURN OFF GAS TO APPLIANCE</h1>	<h1 style="text-align: center;">INSTRUCTIONS DE MISE EN MARCHÉ</h1>		
<p>Cet appareil fonctionne à la fois sur une alimentation a. c. et c. c.</p> <p>Utiliser uniquement un antigel de chaudière à base de propylène glycol non toxique avec des additifs généralement jugés sans danger « GJSD » (« GRAS » / generally recognized as safe) par la FDA.</p> <p>Ne pas hiverner l'appareil de chauffage lorsqu'il est entreposé à des températures inférieures à 0 ° C provoquera de graves dommages au système de chauffage d'eau chaude domestique du produit.</p> <p>La pression d'air appliquée au réservoir ne doit pas dépasser 20 psi. Tout excès de pression provoquera des dommages internes.</p> <p>Pour des informations détaillées, consulter le manuel d'utilisation et contacter Aqua-Hot Heating Systems, Inc. en composant le 800-685-4298.</p>	<p>A. Cet appareil ne comporte pas de veilleuse. Il est muni d'un dispositif d'allumage qui allume automatiquement le brûleur. Ne tentez pas d'allumer le brûleur manuellement.</p> <p>B. AVANT DE FAIRE FONCTIONNER, renifiez tout autour de l'appareil pour déceler une odeur de gaz. Renifiez près du plancher, car certains gaz sont plus lourds que l'air et peuvent s'accumuler au niveau du sol. QUE FAIRE SI VOUS SENTEZ UNE ODEUR DE GAS :</p> <ul style="list-style-type: none"> <li>- Ne pas tenter d'allumer d'appareil.</li> <li>- Ne touchez à aucun interrupteur ; ne pas vous servir des téléphones se trouvant dans le bâtiment.</li> <li>- Appelez immédiatement votre fournisseur de gaz depuis un voisin. Suivez les instructions du fournisseur.</li> <li>- Si vous ne pouvez rejoindre le fournisseur, appelez le service des incendies.</li> </ul> <p>C. Ne poussez ou tournez la manette d'admission du gaz qu'à la main; ne jamais utiliser d'outil. Si la manette reste coincée, ne pas tenter de la réparer; appelez un technicien qualifié. Le fait de briser la manette ou de la réparer peut déclencher une explosion ou un incendie.</p> <p>D. N'utilisez pas cet appareil s'il a été plongé dans l'eau, même partiellement. Faites inspecter l'appareil par un technicien qualifié et remplacez toute partie du système de contrôle et toute commande qui ont été plongés dans l'eau.</p>	<ol style="list-style-type: none"> <li>1. Turn off all electric power to the appliance if service is to be performed.</li> <li>2. Set all interior thermostats to their lowest setting.</li> <li>3. Turn the gas control knob located on the heater's propane inlet port clockwise to the "OFF" position.</li> </ol>	<ol style="list-style-type: none"> <li>1. ARRÊTEZ! Lisez les instructions de sécurité sur la portion à gauche de cette étiquette.</li> <li>2. Cet appareil est muni d'un dispositif d'allumage qui allume automatiquement le brûleur. Ne tentez pas d'allumer le brûleur manuellement.</li> <li>3. Assurez-vous que la sou-pape de contrôle de gaz est bien ouverte. Passez à l'étape B des instructions de sécurité sur la portion à gauche de cette étiquette. S'il n'y a pas d'odeur de gaz, passez à l'étape suivante.</li> <li>4. Référez au Manuel du propriétaire pour des informations au sujet du fonctionnement normal de ce système de chauffage.</li> <li>5. Si l'appareil ne fonctionne pas, veuillez suivre les instructions « Pour couper le gaz vers l'appareil » ci-dessous sur cette étiquette et référez à la section Dépannage du Manuel du propriétaire ou appelez le service de soutien technique au 1.800.685.4298.</li> </ol>		
<p>Ne pas hiverner l'appareil de chauffage lorsqu'il est entreposé à des températures inférieures à 0 ° C provoquera de graves dommages au système de chauffage d'eau chaude domestique du produit.</p> <p>La pression d'air appliquée au réservoir ne doit pas dépasser 20 psi. Tout excès de pression provoquera des dommages internes.</p> <p>Pour des informations détaillées, consulter le manuel d'utilisation et contacter Aqua-Hot Heating Systems, Inc. en composant le 800-685-4298.</p>	<p><b>Aqua-Hot</b> <b>250P</b></p>    <p><a href="http://www.aqua-hot.com">www.aqua-hot.com</a></p>	<h1 style="text-align: center;">COMMENT COUPER L'ADMISSION DE GAZ DE L'APPAREIL</h1>	<ol style="list-style-type: none"> <li>1. Coupez l'alimentation électrique de l'appareil s'il faut procéder à l'entretien.</li> <li>2. Réglez tous les thermostats intérieurs à leur réglage le plus bas.</li> <li>3. Tournez le bouton de contrôle du gaz, situé sur le port d'entrée de propane du chauffe-eau, vers la droite à la position « OFF » (Arrêt).</li> </ol>		

200P/250P Features

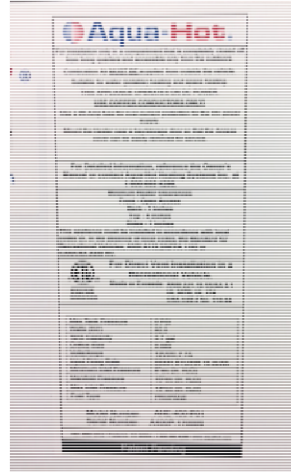

**Note:** The product label attached to each Aqua-Hot provides a ready reference to specifications, test standards, and important safety notices.

**Propane Burner**

Heat Input (Firing Rate)	60,000 BTU/h
Fuel Consumption (Continuous)	0.66 g/h
Typical Consumption (Average)	0.33 g/h

**Electric Heating Element (250P Only)**

Specifications	120 VAC/1000 W
----------------	----------------

**Voltage/Maximum Power Consumption**

Specifications	12 VDC/42 W
----------------	-------------

**Zone Heat Circulation**

Pumps	1
Voltage/Maximum Power Consumption	12VDC/21 W

**Heating Zones**

Maximum	1
---------	---

**Domestic Water Heating**

Capacity with continuous supply	1.5 Gal/Min
---------------------------------	-------------

**Specifications**

Dimensions	11.69"H x 12.45"W x 21.61"L
Dry Weight	84 lbs.
Wet Weight	104 lbs.

**NOTICE**

All vehicle installations must comply with the requirements listed in the Recreational Vehicle Industry Association's (RVIA) ANSI/NFPA 1192 Handbook for Recreational Vehicle Standards. To receive a copy of this handbook and other pertinent RVIA Standards, write to: Recreation Vehicle Industry Association, 1896 Preston White Drive, P.O. Box 2999, Reston, VA 22090-0999, call them at (703) 620-6003, or online at [www.rvia.org](http://www.rvia.org), [www.nfpa.org](http://www.nfpa.org).



For installation only in a compartment that is completely closed off from living quarters and accessible only from the outdoors.

Combustion Air **MUST BE** supplied from outside the vehicle. Suitable for water (potable) heating and space heating. THIS APPLIANCE OPERATES ON DC POWER.

**USE COPPER CONDUCTORS ONLY!**

Use a 20-Amp fuse for over-current protection for the DC power supply.

Mount the Heater near a bay/storage door so that the Access cover can be easily removed for service.

**For Detailed Information, reference the Owner's Manual or contact Aqua-Hot Heating Systems Inc. at 1-800-685-4298.**

**Minimum Service Clearances**  
 Front - Open Access  
 Back - 1 Inches  
 Top - 8 inches  
 Sides - 1 inches

This appliance must be installed in accordance with local codes or, in the absence of local codes, the Standard for Recreational Vehicles, ANSI A119.2/NFPA 1192 or CAN/CSA-Z240 RV.

 **For Direct Vent Installation in a Recreational Vehicle.**  
 Meets or Exceeds: ANSI Z21.10.1/C SA 4.1  
 UL 307B, UL 174  
 CSA-C22.2 No. 110-94

Max Tank Pressure	0 PSI
Watts (DC)	92.5
Tank Capacity	3.7 gal
Orifice Size	0.089
Volts/Amps	12VDC, 7.7A
Input Firing Rate	60000 BTU/HR, 17.6 kW/h
Minimum Inlet Pressure	8"wc (in. H <sub>2</sub> O)
Manifold Pressure	10"wc (in. H <sub>2</sub> O)
Max Inlet Pressure	13"wc (in. H <sub>2</sub> O)
Fuel Type	PROPANE

Model Number: 200P  
 Serial Number: A200-170002

7501 Miller Drive • Frederick, CO 80504 • 1.800.685.4298 • [www.aquahot.com](http://www.aquahot.com)

**Patent Pending**

### Heater Components

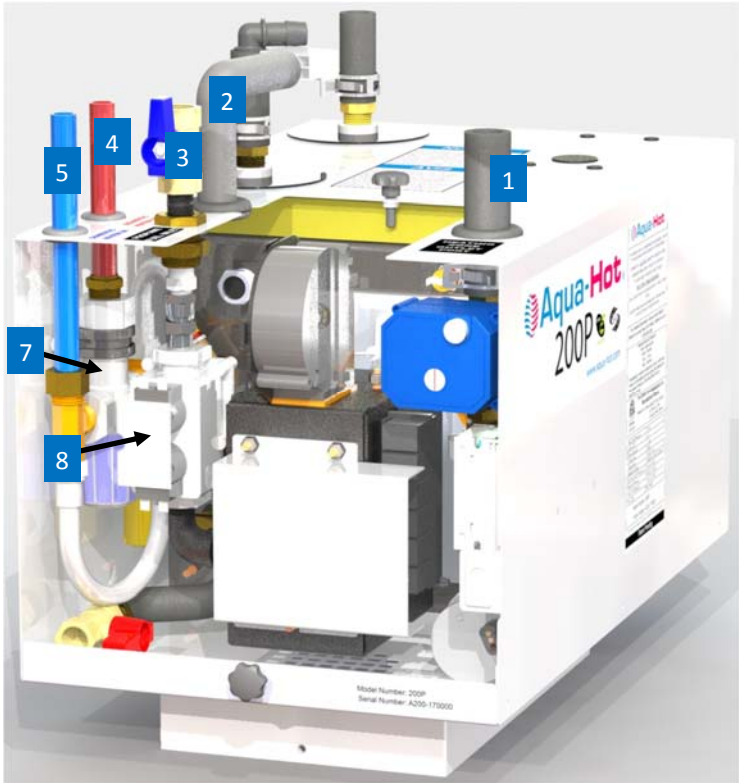

1. Heating zone outlet port
2. VDC main wiring harness
3. Propane fuel inlet
4. Domestic water outlet port (hot)
5. Domestic water inlet port (cold)
6. Heating zone inlet port
7. Expansion bottle outlet port
8. Interlock door switch
9. Access cover
10. AC Relay Enclosure (250 only)

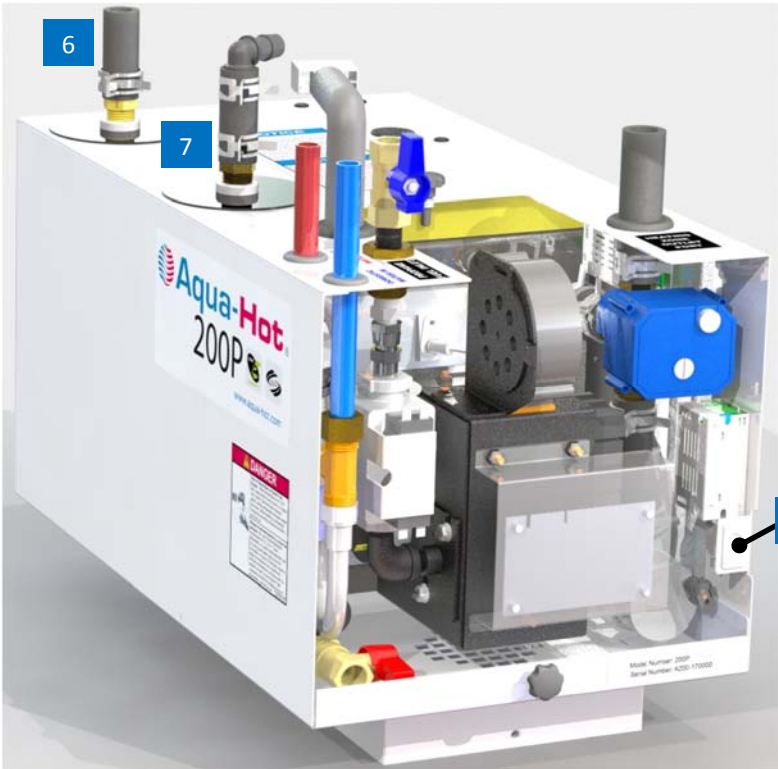
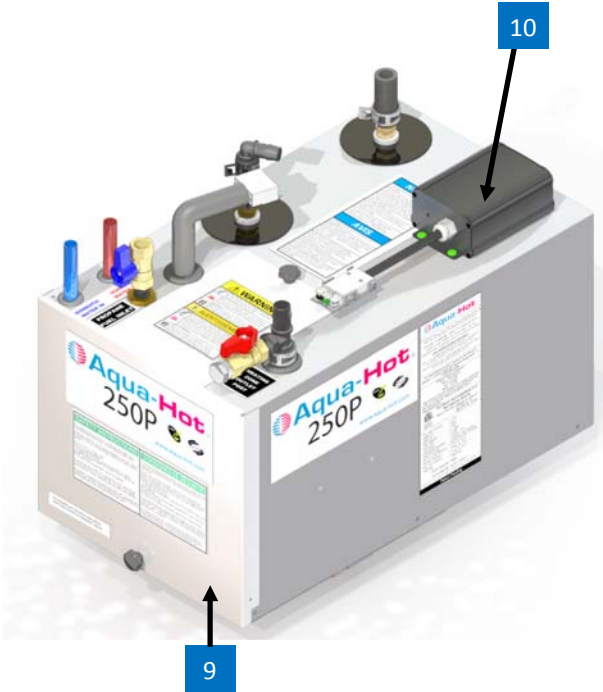

**NOTE:** Service parts and accessories are available through Aqua-Hot Factory Authorized Service Center or at [www.aquahot.com](http://www.aquahot.com)



## Installing the Aqua-Hot

The Aqua-Hot must be installed in a compartment that is completely closed off from living quarters and accessible only from the outdoors.

1. Reference the following illustrations for mounting information:
2. Cut out the required mounting flange opening. Reference Figure 2.
3. Install the flange on the bottom of the Aqua-Hot into the cut-out opening. Reference Figures 2 and 3.
4. Take the angle brackets and included 1/4-20 bolts and washers and install the angle brackets into the nuts found on the flanges.

- Front View Aqua-Hot dimensions. Reference Figure 1.
- Floor cut-out information. Reference Figure 2.
- I.D. Label noting the "Open Access" clearance requirement for the front of the heater. Reference Page 8.
- Service access clearance. Reference I.D. Label on Page 8.

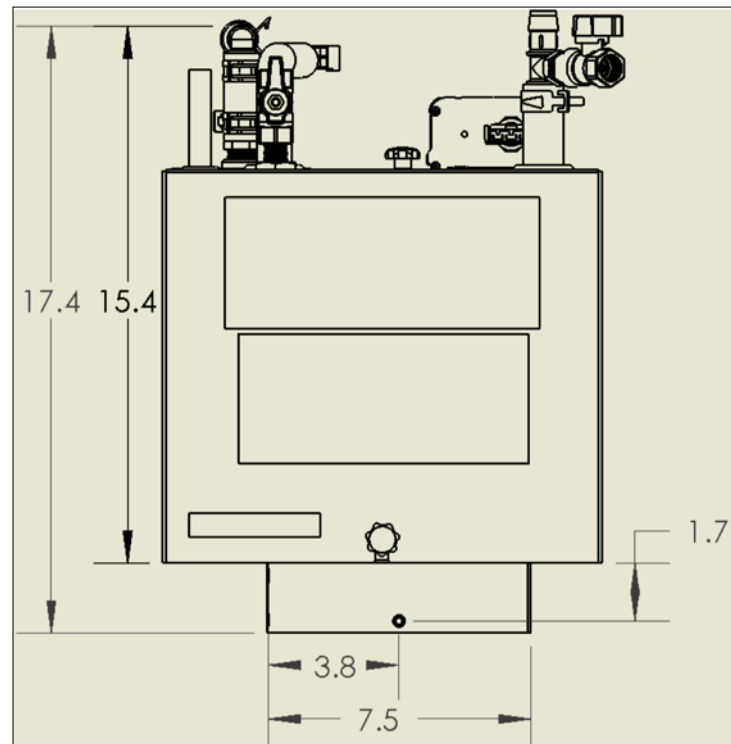

Figure 1. Front View Aqua Hot Dimensions

**NOTE:** Be sure to complete the following when installing the Aqua-Hot:

Inspect the area beneath the mounting location to ensure that no structural members will interfere with the cut-out for the mounting flange.

Verify that an adequate support system has been provided for the Aqua-Hot.

Figure 2: Floor cutout and installation clearances

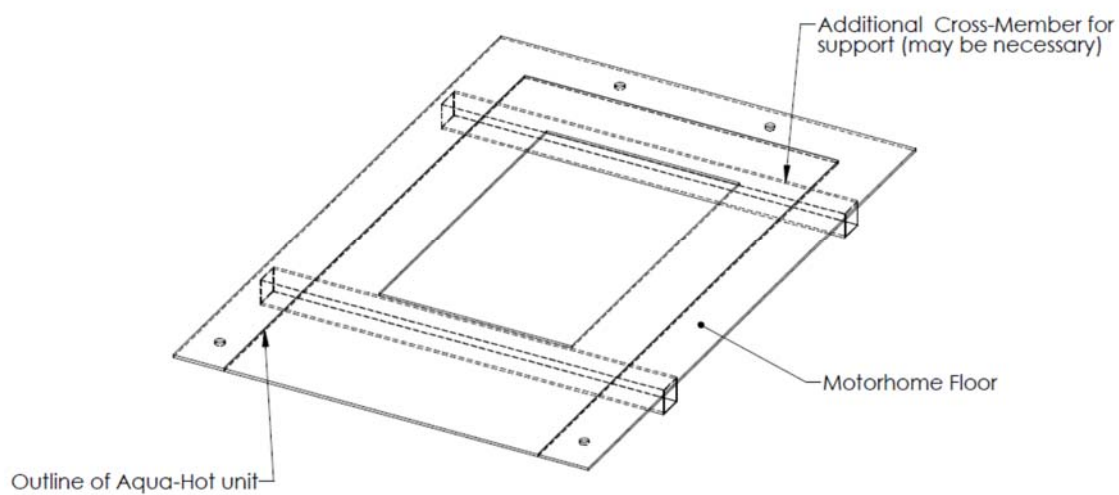
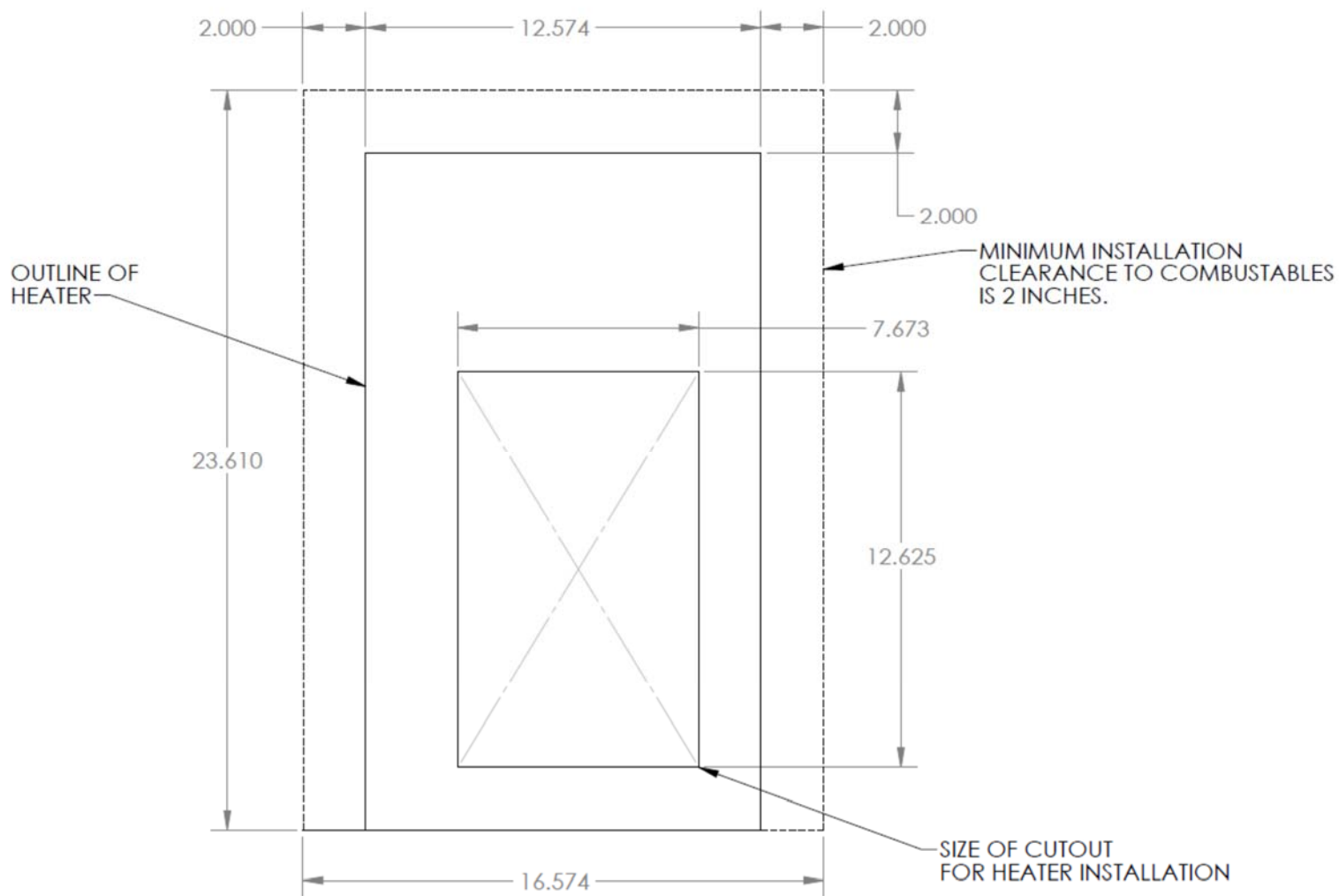
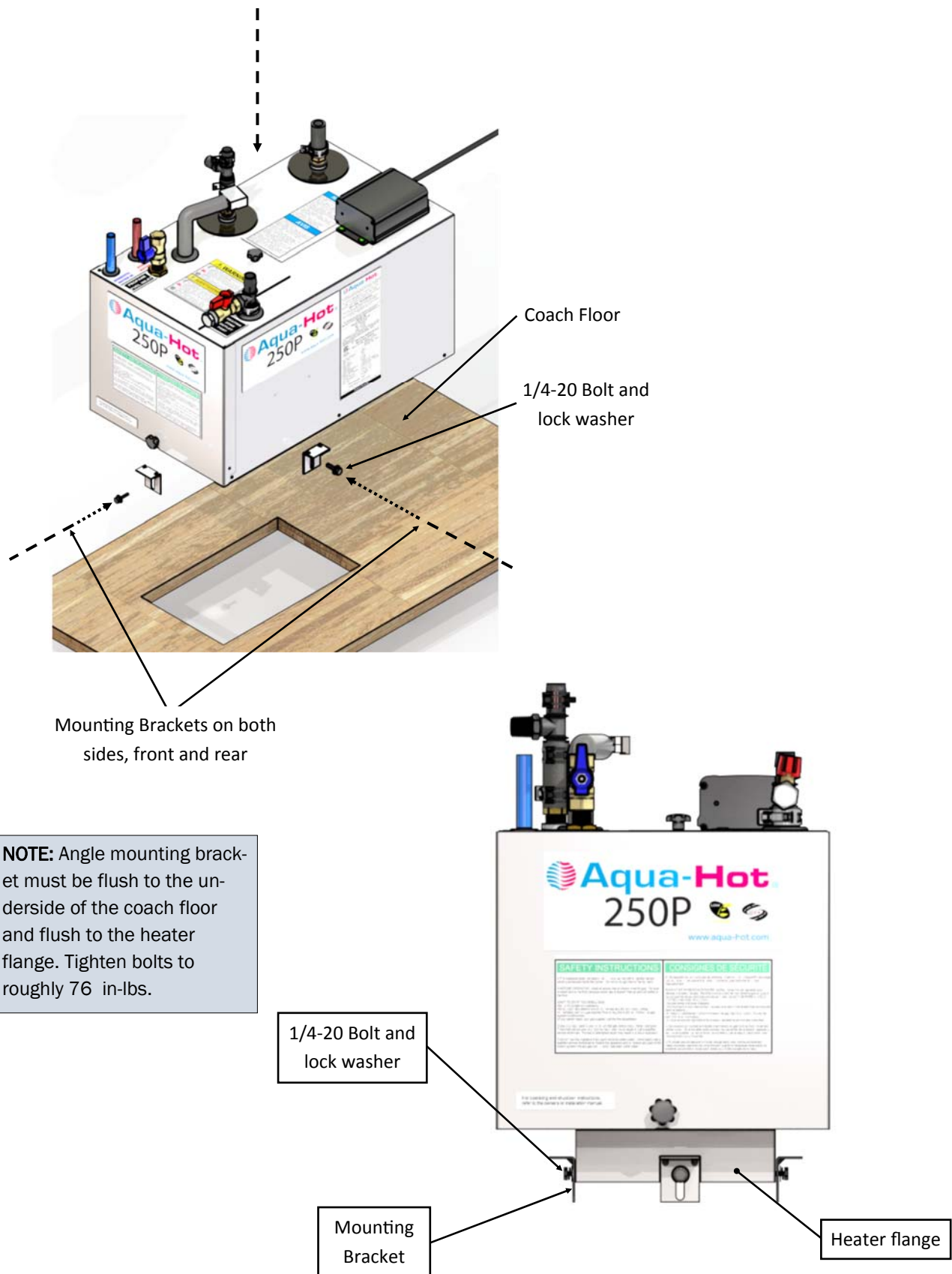

Figure 3: Heater installation into coach floor





## Pressure Testing the Aqua-Hot:

### **CAUTION**

The Aqua-Hot tank and heating loop operates at 0.0 psi (zero pressure system). Air pressure applied to the tank **MUST NOT** exceed 20 psi. Excess pressure will result in internal damage.

## Installing the Expansion Tank

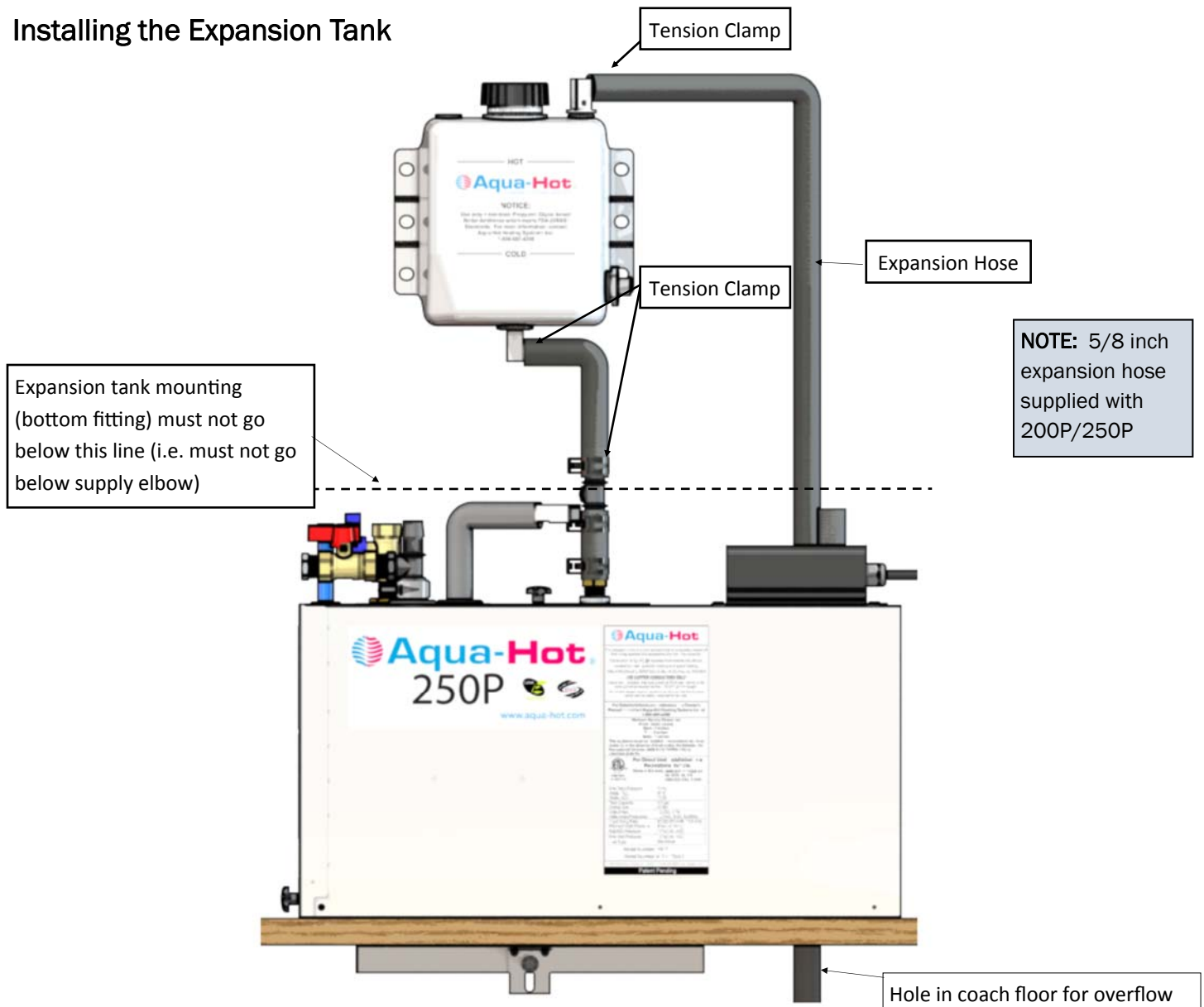

**Figure 4: Expansion bottle installation**

Select a mounting location that allows for easy access and clear visibility whenever the particular storage bay door is open.

1. Mount the expansion tank as illustrated in Figure 4.
2. Connect and clamp the overflow tubing from the expansion tank to the Aqua-Hot's expansion tank connection. Reference Figure 4.
3. Drill a hole in the bay floor and connect (secure with a clamp) a long piece of overflow tubing so that it can be connected to the top of the expansion tank and extend through the bay floor.

**NOTE:** Avoid any dips and bends in the overflow tubing from the Aqua-Hot to the expansion tank as air can become trapped in these dips and bends. This will prevent the expansion of the heating solution from properly depositing in the expansion tank.

Figure 7A: Heat exchanger installation locations

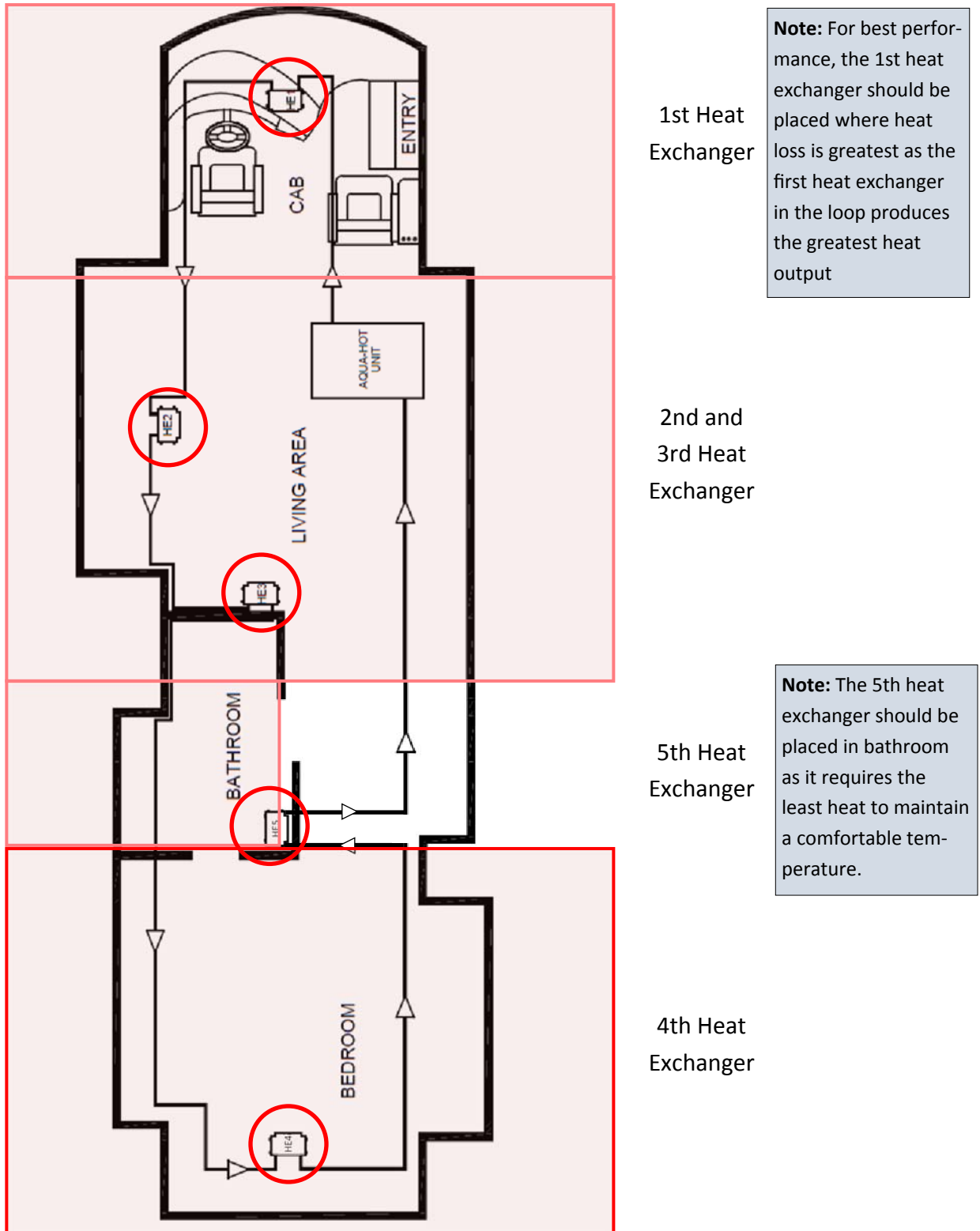

### Mounting Requirements

Sufficient ventilation (return-air) must be supplied to each interior heat exchanger. Reference Figure 8.

**NOTE:** Ventilation (return air) must be supplied from the living area. Ventilation (return air) MAY NOT be supplied from the bay area.

**NOTE:** Mounting the heat exchangers without sufficient ventilation will severely reduce their overall heating performance (heat output).  
In order to provide sufficient ventilation, the return air registers must be the same size, or larger than the outlet-register,  
Return-air must be supplied from the corresponding interior heating zones.

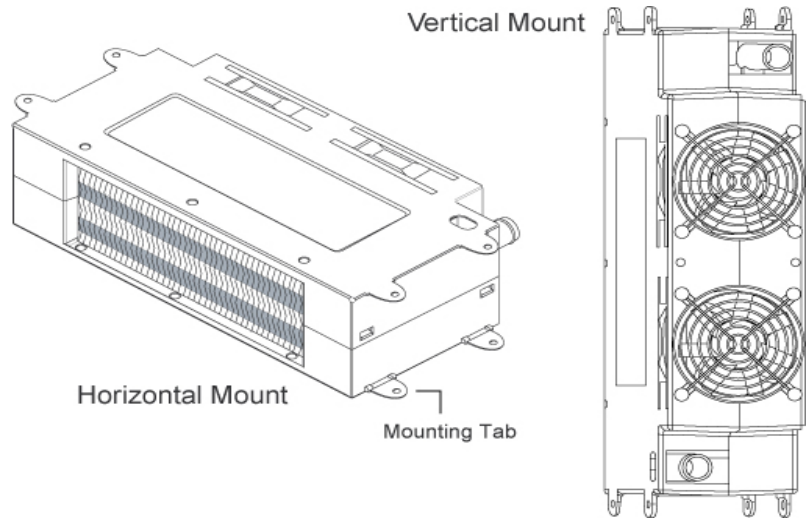

Figure 11: Cozy Heat Exchanger mounting

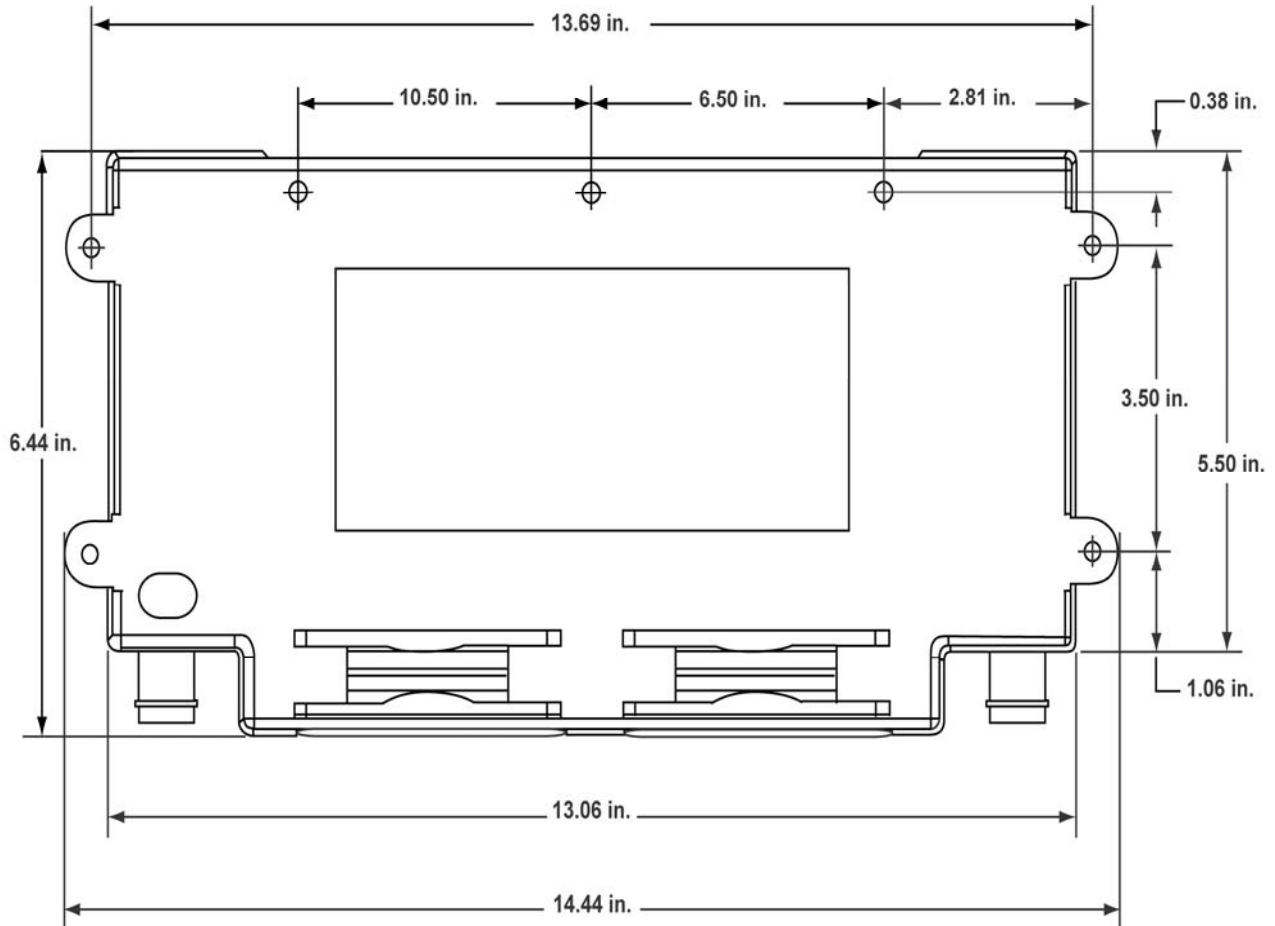

Figure 12

## Mounting the Heat Exchangers

1. Cut out a 2.5 inch H x 10 inch W opening for each heat exchanger outlet and cold-air return register.
2. Mount each heat exchanger permanently into place. Reference Figures 11 and 12.
3. Install the hot-air outlet and cold-air return registers. Reference Figure 8.

**NOTE:** Please note that a return-air register may not be required; however, adequate return-air must be provided to each particular heat exchanger. This means that the total cross-sectional area of the return-air opening must be equal to or greater than the cross-sectional area of the hot-air outlet opening of the heat exchanger.

Figure 8

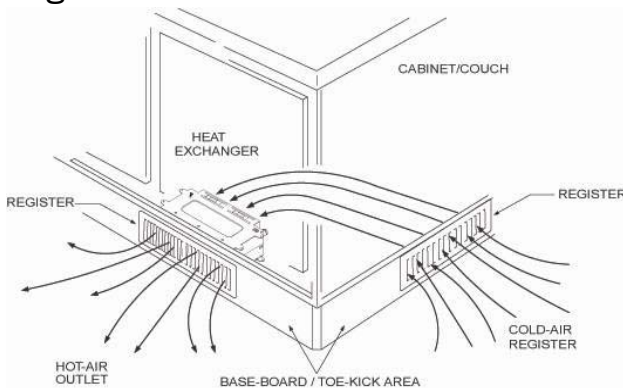
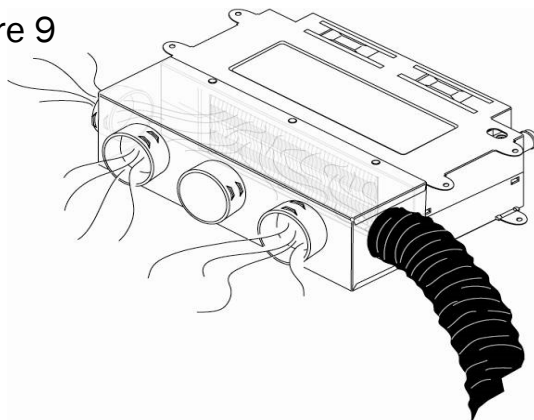
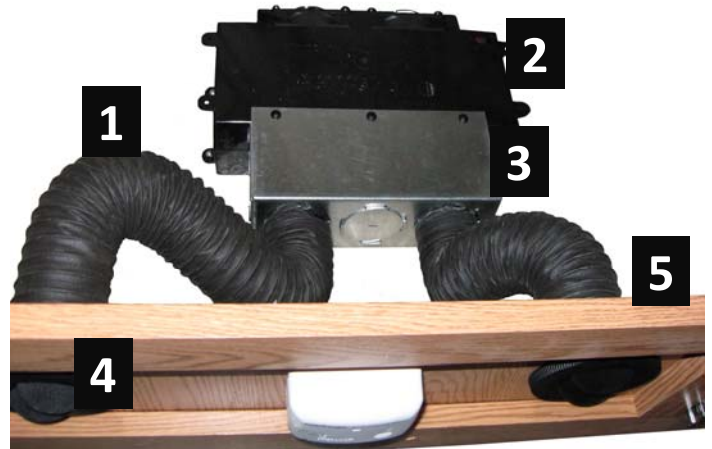

Figure 9



If the toe-kick areas in the motor home are inadequate to house a heat exchanger for regular installation, a plenum may be used on the heat exchanger, which can be used with a smaller vent as seen in Figure 10. The plenum allows only the desired outlets to be opened by removing the metal insert on the vent.

Figure 10



1. Hose to direct air to vent
2. Cozy Heat Exchanger
3. Plenum
4. Vent Installed In Toe-Kick area
5. Toe Kick Board

## Heat Exchanger Locations and Clearances

Place the heat exchangers so that even heat distribution will be felt throughout the interior of the motor home. Reference Figure 7A.

**NOTE:** For single slide-out configurations, it is usually simplest to place a heat exchanger on the opposite side of the motor home pointing towards the slide-out.

Place the heat exchangers where they will be accessible for potential servicing and cleaning.

If used for bay heating, centralize and position a heat exchanger in the fresh water storage tank plumbing bay.

**NOTE:** In order to achieve the best heating results, place the heat exchanger as close to the floor of the plumbing bay as possible (heat will naturally rise). Reference Figure 6.

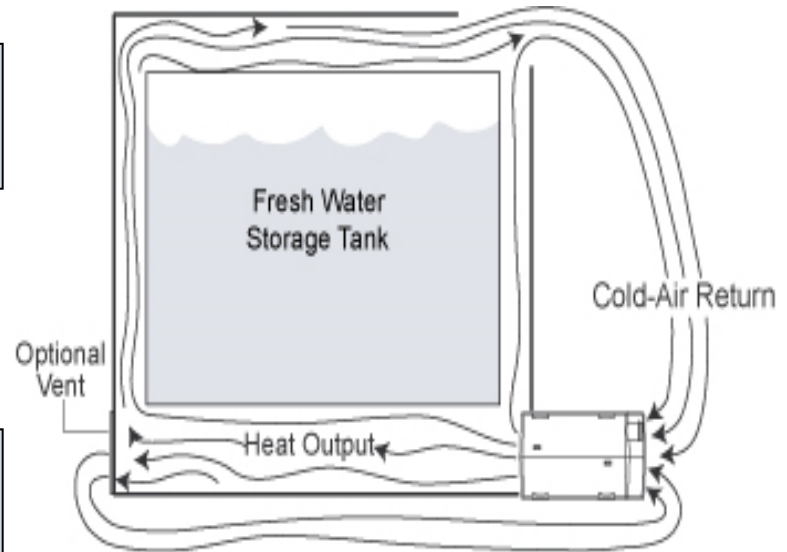

Figure 6

Reference Figures 7, 7A, and 8, for mounting location information. Reference Figure 7 for clearance information.

**NOTE:** An accessory device (Plenum) is available for the Cozy Heat Exchanger for the purpose of redirecting the airflow from the heat exchanger. Reference Figures 9 and 10.

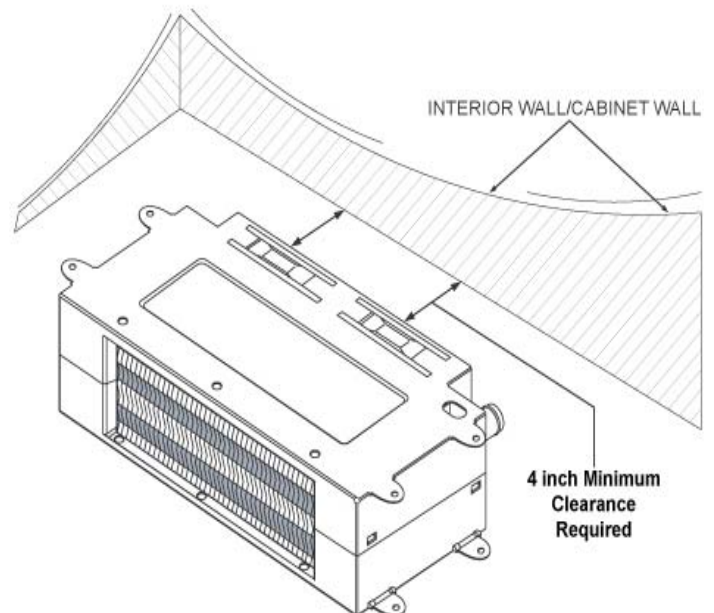

Figure 7

## Optional Bay Heating

A 6th cozy may be added to provide bay heating for the coach (Figure 6). An additional pump (Boost Pump) is required to maintain satisfactory coolant flow for interior heating performance. (Figure 7C).

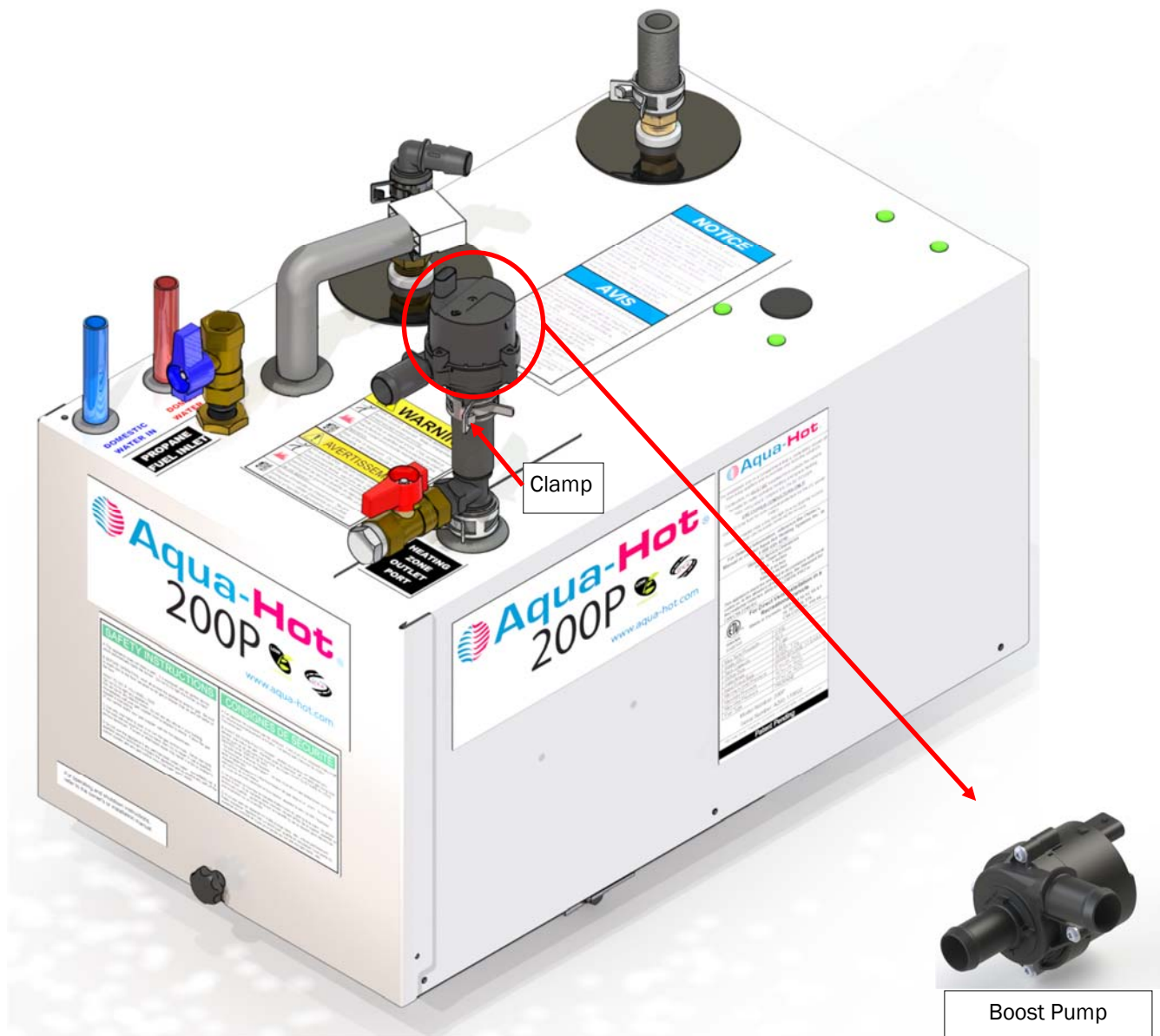

Figure 7C: 3D depiction of AH-250P with boost pump

**NOTE:** Please reference page 19, figure 13 for pump operation. Pin 7 (orange) must be used to operate pump. This will provide boost coolant flow when coach heating circuit is energized.



## Wiring the Heat Exchangers—Aqua-Hot Controls

1. Wire all the heat exchangers in a parallel circuit inside the coach (i.e. all heat exchangers share a common power wire and a common ground wire).
2. With the farthest heat exchanger from the Aqua-Hot, run the power wire back to the eight pin connector and plug it into pin #7.
3. With the farthest heat exchanger from the Aqua-Hot, run the ground wire back to the eight-way pin connector and plug it into pin #8.
4. With the remaining heat exchangers, tap the power from each exchanger into the previously connected power wire that is running back to the Aqua-Hot.
5. With the same heat exchangers, tap the ground from each exchanger into the previously connected ground wire running back to the Aqua-Hot. If there are any issues with the wiring, please contact Aqua-Hot.
6. Reference Figures 14 and Table 1 (page 32)

Figure 13: Aqua-Hot eight-way pin out connector

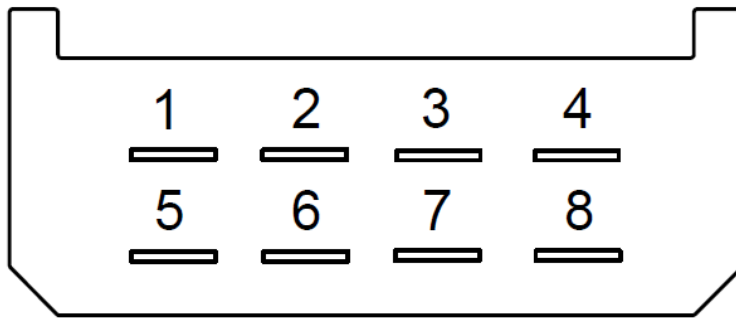

Pin	Vehicle Side	Aqua-Hot Side	Wire Color
1	12 VDC (20 A Fused) from vehicle	System Power	Red
2	Vehicle Ground	System Ground	Black
3	12 VDC Return Signal from Burner Switch	Main System Relay (#1)	White
4	12 VDC Output to Burner Switch	System Power	White
5	12 VDC Output to room thermostat	Power from Main System Relay	Blue
6	12 VDC Return from room thermostat	Interior Heat Relay (#2)	Green
7	12 VDC Output to heat exchangers	Signal to valve and interior heat relay (#2 and #3)	Orange
8	12 VDC Return from heat exchangers	System Ground	Black

**Wiring the Heat Exchangers – OEM RV-C or Multiplex Zone Control Systems.**

When choosing a zone control for the heat exchangers the following must be adhered to or the Aqua-Hot will not function correctly in the domestic water heating mode of operation.

“Interior Heat” Pin 6 must be supplied with +12vdc so that the Aqua-Hot 200/250 controls will provide coolant flow to the heating zone.

Furthermore, Pin 7 must be integrated into the OEM control of the zone/cozy fan on/off control. Pin 7 will be +12Vdc when there is a call for interior heat. However, this connection will also drop the +12Vdc when domestic water flow is sensed (within the Aqua-Hot system controls - wiring). This enables the complete heating power to be prioritized for shower comfort.

Figure 14: Cozy heat exchanger wiring

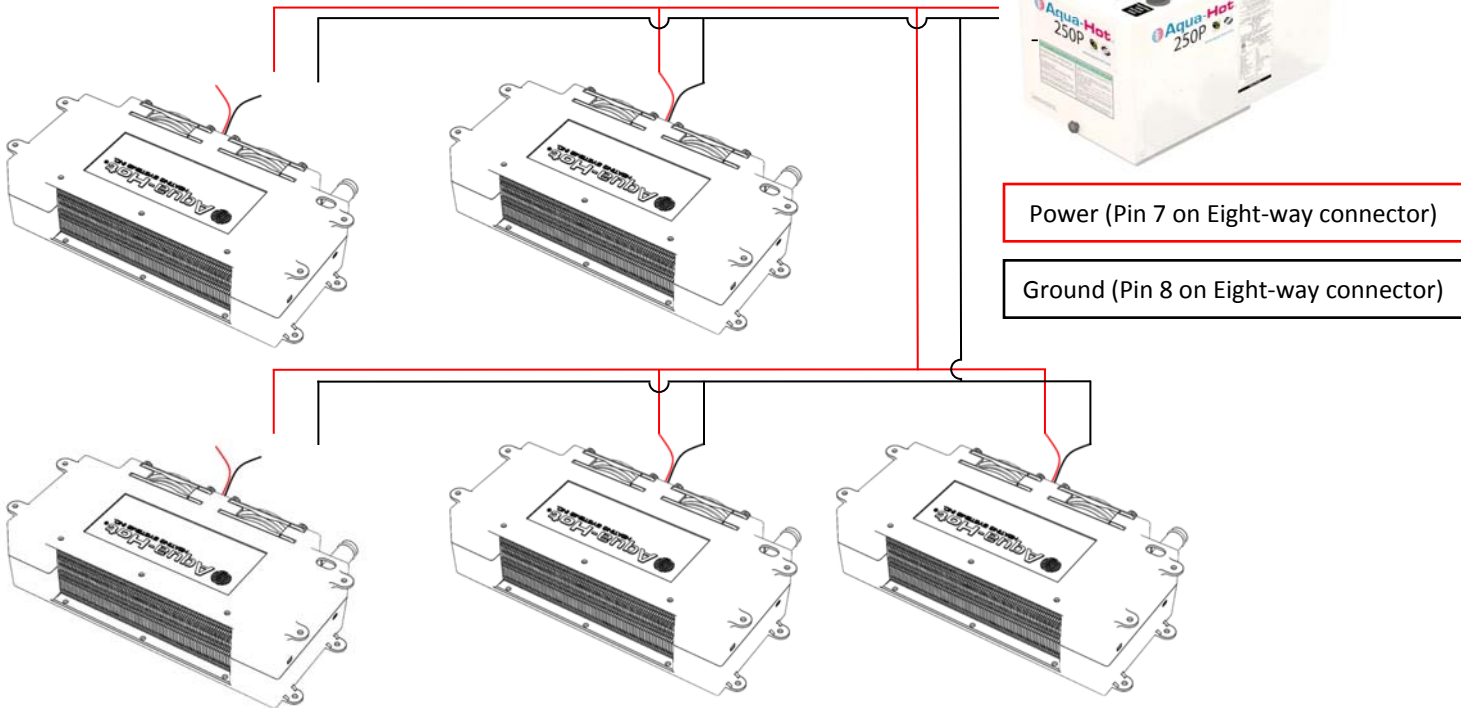

Figure 15



When wiring the heat exchanger in-parallel, the main 18-gauge wire is split to allow the heat exchanger wires to combine with the main wire to be powered or grounded, respectively.



## Plumbing the Hydronic Heating System

**NOTE:** All plumbing lines should be laid as flat as possible, and any extreme rises in height should be avoided to eliminate any potential air-traps.

**NOTE:** Use 5/8 inch I.D. (inside diameter) plumbing lines (SAE J20 Type Hose) for both heating loops. Use wide-sweeping elbows or “bend supports” whenever the plumbing lines may be susceptible to kinking (i.e., 90° bends).

**NOTE:** When exceeding 5 heat exchangers or for longer coolant line lengths a boost pump in the coolant system will be required

1. Lay out the plumbing lines for all heat exchangers.
2. Label each line and designate as an inlet or an outlet line.
3. Connect and clamp the outlet line from the heater to the lowest port (inlet port) on the first heat exchanger. Reference Figure 17.
4. Connect and clamp a line from the first heat exchanger’s highest port (outlet port) Then, connect the other end of the line to the second heat exchanger’s lowest port (inlet port).
5. Connect each additional heat exchanger in the same arrangement (low to high).

**NOTE:** Run all the plumbing lines in areas where they cannot be pinched off or damaged under normal operating conditions.

Be sure to secure all lines where necessary and apply protective shielding in areas where chafing may occur.

Rubber Coated/Closed-Type clamps are recommended when securing the plumbing lines.

6. Connect and clamp the inlet line from the heater to the highest port on the last heat exchanger to complete the heating loop. Reference Figure 17.

**NOTE:** Reference Figure 19 for visual instructions on connecting the PEX-Type tubing to each heat exchanger.

Plumbing heat exchangers in this manner will allow air to escape naturally. If air is trapped in any heat exchanger, it will significantly reduce the heat exchanger’s overall heating performance (heat output).

7. Connect and tighten all interior plumbing lines, outlet and inlet, to the Aqua-Hot’s heating loop ports. Reference Figure 19 and Figure 20.

**NOTE:** The inlet and outlet plumbing lines can be installed with a straight fitting or an elbow fitting.

Figure 17  
Cozy Heat Exchanger  
(Rear View)

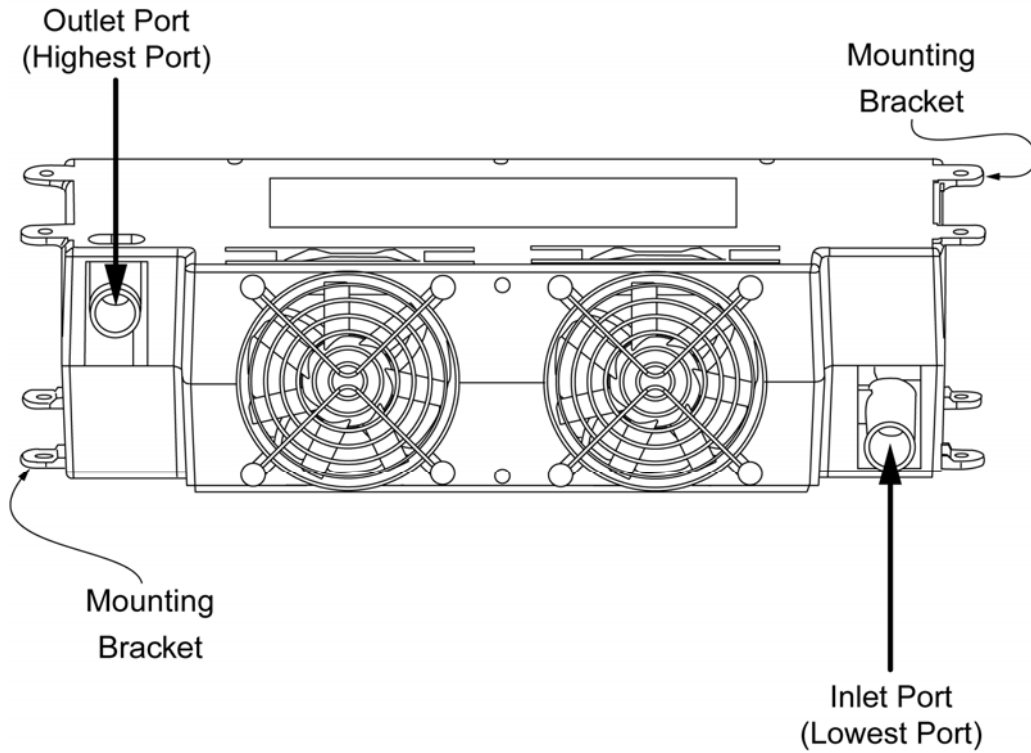
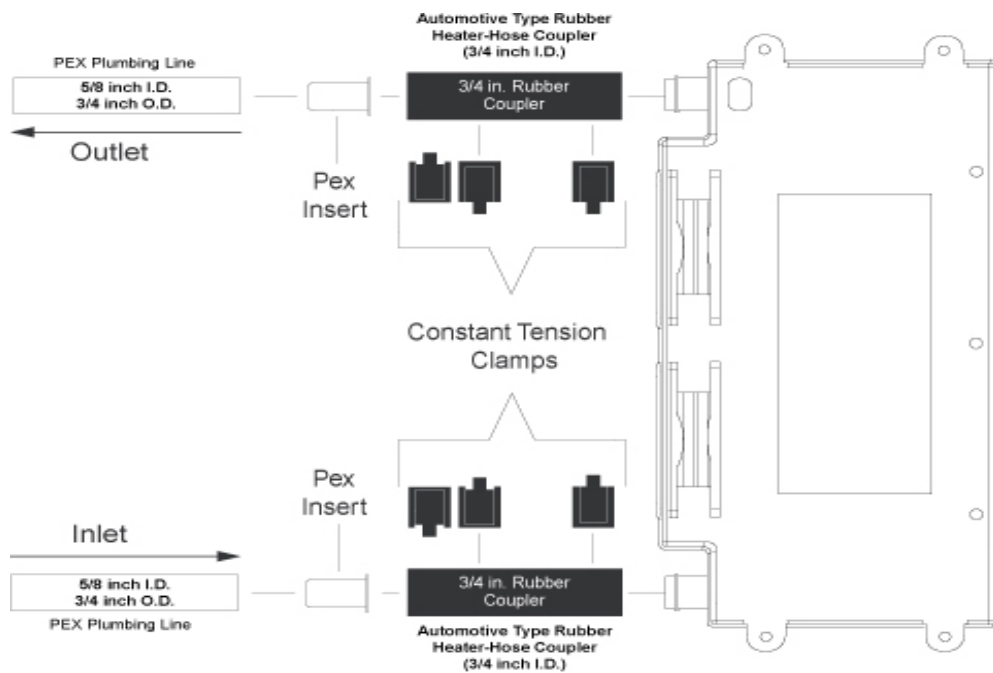
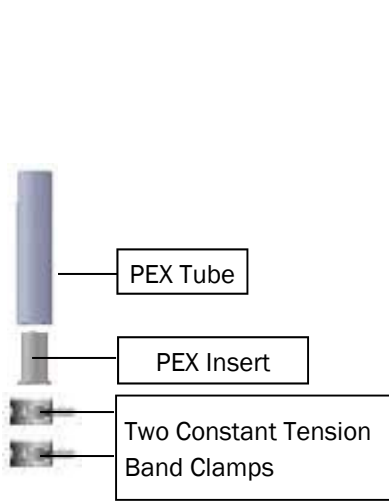

Figure 19



### Inlet and Outlet Heating Loop Connection Examples

Figure 20



Straight Connection Components

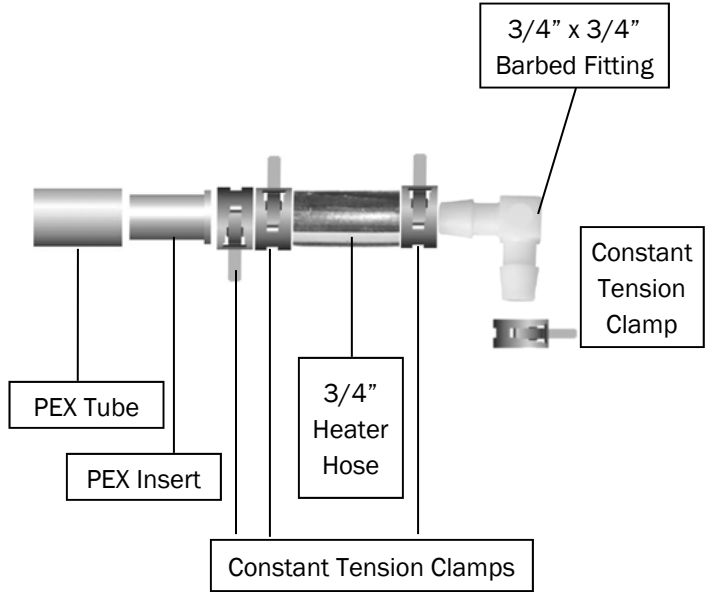

90° Connection Components



Straight Connection Components Installed (AC Electrical box is hidden to show connections on zone return port.)

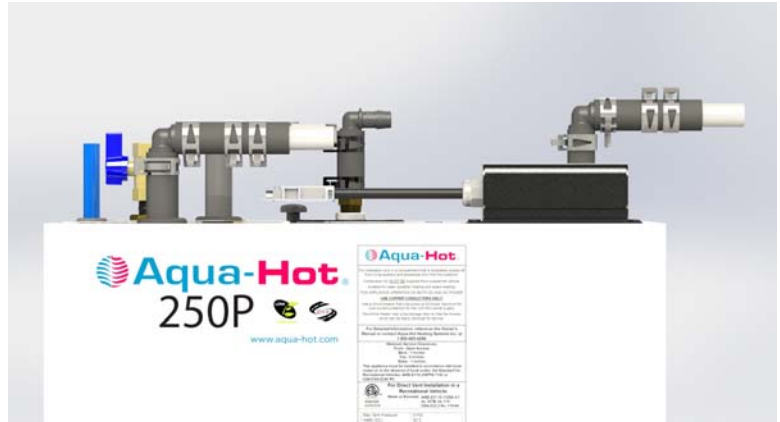

90° Connection Components Installed

## Domestic Water System Requirements

Reference A119.2/NFPA 501C Standard on Recreation Vehicles, 1993 Edition for domestic water systems.

**NOTE:** The Aqua-Hot is equipped with a pressure-relief valve, which releases excessive pressure in the domestic water system, if necessary. A tempering valve is also needed in order to regulate the temperature of the hot water.

**NOTE:** To ensure consistent water temperature, shower fixtures shall be regulated for a flow of 1.5gpm or less.

Figure 21

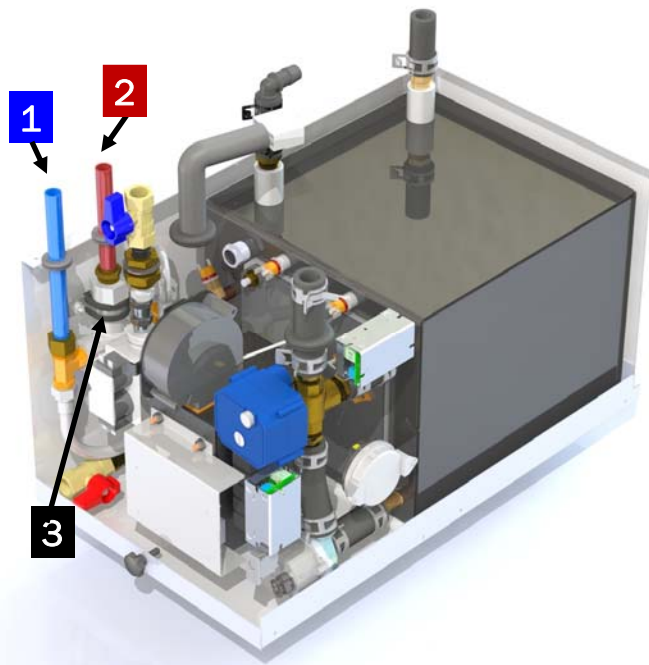

1. Domestic Cold Water Inlet
2. Domestic Hot Water Outlet
3. Tempering Valve

## Domestic Water System Plumbing

1. Connect a domestic water plumbing line from the domestic water demand pump/water manifold to the cold water inlet port (blue PEX tube) on the Aqua-Hot. Reference Figures 20 and 21.
2. Connect a domestic water plumbing line from the Aqua-Hot's hot water outlet port (red PEX tube) to the hot water system's distribution lines/water manifold. Reference Figures 20 and 21.

# NOTICE

Aqua-Hot systems contain copper tubing and are not compatible to prolonged exposure to sodium hypochlorite (bleach or liquid bleach). Using products containing bleach, including water refreshers, may cause corrosion of the domestic water coil, resulting in a catastrophic failure of the Aqua-Hot system by creating leaks that cannot be repaired. This damage is not covered by the Aqua-Hot warranty.

## Switch Panel Location

1. Installation must conform to NFPA 1192-2018
2. Select a location in the interior of the coach that allows for easy unobstructed operator access.

## Switch Panel Mounting

1. Cut out a 1.0" W X 1.75" H opening for the switch panel plate. Reference Figure 23.
2. Once the switch panel has been completely wired, permanently mount the switch panel in place.
3. Move both switches to an OFF position by pressing them in a downward motion.

## Switch Panel Wiring

**NOTE:** It is recommended that the wire colors illustrated in Appendix A be used when installing the switch panels. This will ensure installation consistency, differentiate between the separate switches, and assist service personnel with troubleshooting. Reference ANSI/RVIA-LV for proper wire-gauge sizing.

1. Run 16-gauge wires from the switch panel to eight-way connector to the Aqua-Hot heater.

**NOTE:** Be sure to attach "Jumper Wires" where necessary. Reference Figure 22A.

2. Strip and crimp insulated female terminals onto each wires at the switch panel location.
3. Connect all switch wires to the appropriate switch connections as illustrated in Figure 22A. Reference Appendix A for additional wiring information.
4. Run the wires from the switch to Pins #3 and #4 on the eight-way connector at the heater (see Fig. 13).

Figure 22

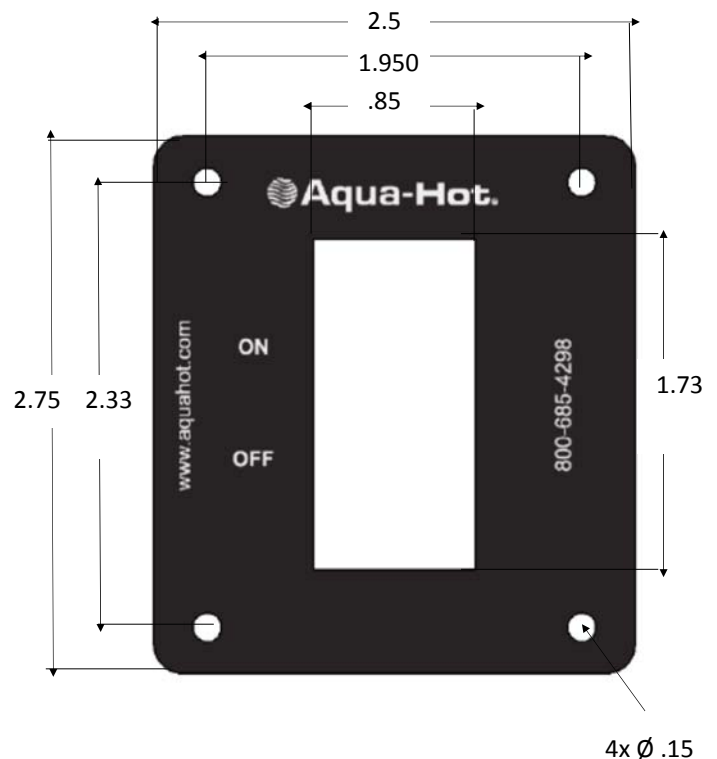

## Switch Panel Location

1. Select a location in the interior of the coach that allows for easy operator access.
2. All electric installations, systems, and equipment shall comply with Article 551, Parts I and III through VI of NFPA 70, as well as the regulation of authorities having jurisdiction and CSA Standard B139.

## Switch Panel Mounting

1. Cut out a 3.75" W X 1.25" H opening for the switch panel plate. Reference Figure 26.
2. Once the switch panel has been completely wired, permanently mount the switch panel in place.
3. Move both switched to an OFF position by pressing them in a downward motion.

## Switch Panel Wiring

**NOTE:** It is recommended that the wire colors illustrated in Appendix A be used when installing the switch panels. This will ensure installation consistency, differentiate between the separate switches, and assist service personnel with troubleshooting. Reference ANSI/RVIA-LV for proper wire-gauge sizing.

1. Run 16-gauge wires from the switch panel to the eight-way connector to the Aqua-Hot heater.

**NOTE:** Be sure to attach "Jumper Wires" where necessary. Reference Figure 23A.

2. Strip and crimp insulated female terminals onto each wires at the switch panel location.
3. Connect all switch wires to the appropriate switch connections as illustrated in Figure 23A. Reference Appendix A for additional wiring information.
4. Run the wires from the switch to Pins #3 and #4 on the eight-way connector at the heater (see Fig. 13).

Figure 23

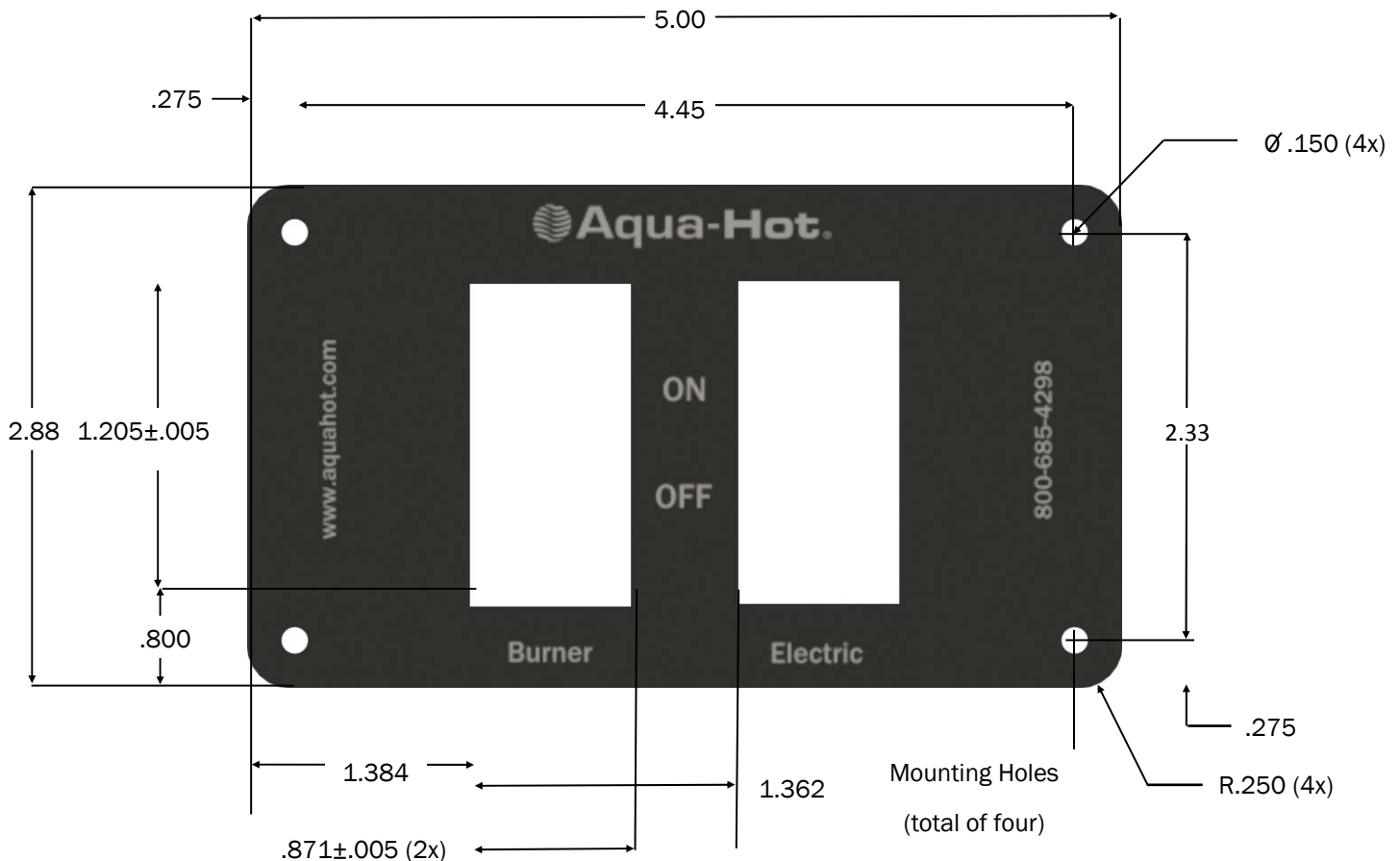

Aqua-Hot 200P Switch Panel, Rear View

Figure 22A

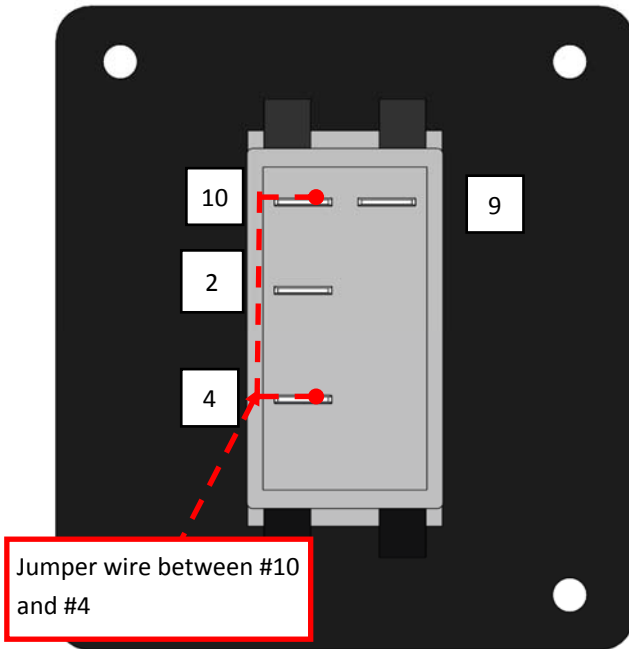

Switch	Eight-Pin Harness Plug
Pin #4	To Pin #3
Pin #2	To Pin #4
Pin #9	To Chassis Ground

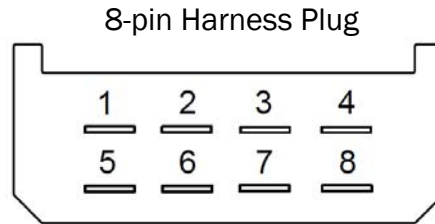

**NOTE:** The burner element switch possess a jumper wire, which advance from terminal 10 to terminal 4.

Aqua-Hot 250P Switch Panel, Rear View

Figure 23A

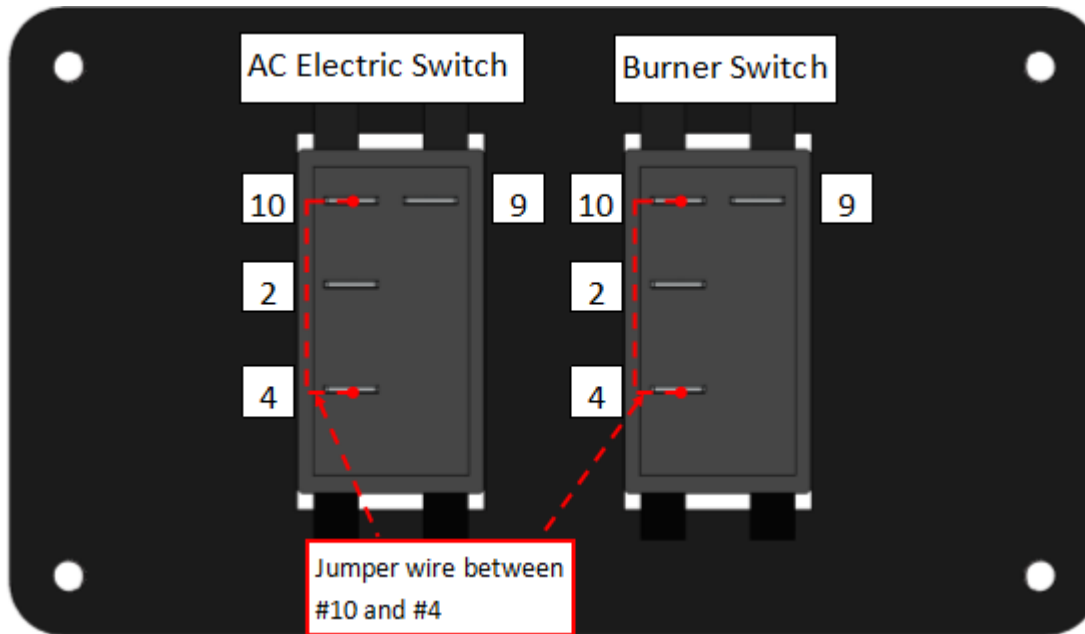

**NOTE:** The burner and electric element switches must possess a jumper wire, which advance from terminal 10 to terminal 4.

AC Electric Switch	AC Control Switch Plug	Burner Switch	Eight-Pin Harness Plug
Pin #4	Pin #1	Pin #4	To Pin #3
Pin #2	Pin #2	Pin #2	To Pin #4
Pin #9	To Chassis Ground	Pin #9	To Chassis Ground

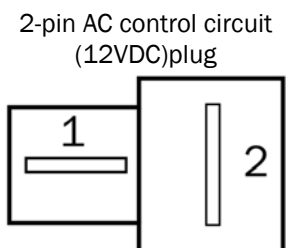

### **WARNING**

Use caution when working on or near the propane gas system.

- Do not smoke or use an open flame near the propane gas system.
- Do not use an open flame to examine for leaks.
- To avoid possible propane gas leaks, always use two wrenches to tighten or loosen the gas supply line connectors.
- Leaking propane can ignite or explode and result in dangerous personal injury or death.
- Ensure that all tubing and fitting obey all local, state, and national codes regarding size and type.
- Ensure that the material used for the propane supply line obey both the current ANSI 119.2 (NFPA1192) AND CSA Z240 Standards on Recreational Vehicles.

Manual Shut-Off Valve for Propane Supply Installed in Propane Inlet Port

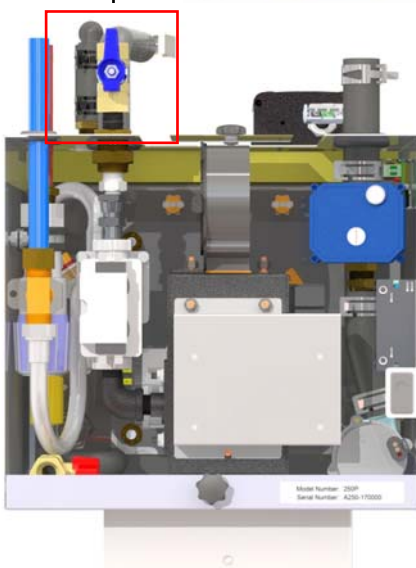

### **WARNING**

1. Run an appropriate size line of an approved material from the propane manifold to the manual shut-off valve installed on the Aqua-Hot's propane inlet port.

**NOTE:** The fuel delivery system must meet the requirements of "NFPA 1192 Standard Recreational Vehicles". For pipe sizing, use NFPA 54/ ANSI Z223.1, which ensures the complete vehicle gas demand/ pipe sizing is considered during the layout of the fuel system. For the 200/250P use an input rating of 70,000btu/hr in calculating fuel pipe "inside diameter" when other propane appliances are installed in the same propane power supply system

2. Tighten both connections thoroughly using two wrenches to ensure that no leaks can occur.

**NOTE:** The Aqua-Hot 200P and the Aqua-Hot 250P must be isolated from the gas supply piping system by closing its individual manual shut-off valve during any pressure testing of the gas supply piping system at test pressures equal to or greater than 1/2 PSI (3.5 kPa).

**NOTE:** Do not use excessive pipe thread compounds when connecting gas line to valve.



## **WARNING**

The Aqua-Hot's exhaust is **HOT** and must be kept away from any heat-sensitive material.

**DO NOT** direct exhaust downward as a fire may result when parked in dry, grassy areas.

Exhaust must not terminate beneath the vehicle or beneath an openable window or vent.

**DO NOT** terminate the exhaust pipe within the awning area of the motor home, if applicable. Be sure to keep the exhaust away from the slide-out areas.



## **CAUTION**

All Aqua-Hot exhaust system installations **MUST** utilize the two black pipe nipples and the black pipe elbow, which are supplied separately from the heating system, in the configuration best suited for the particular recreational vehicle application. Failure to conform could create a hazardous situation and will void the Aqua-Hot's ETL product listing.

**NOTE:** Refer to "Internal Combustion Engine Exhausts and Vehicle Wall Openings" in RVIA'S ANSI/NFPA 1192 Handbook for the Recreational Vehicle Standards, as well as the National Fire Protection Associations' (NFPA) 1192 Standard on Recreational Vehicles for additional information.

### Exhaust System Requirements

1. The exhaust must be able to freely exit away from the vehicle without any obstructions.
2. Angle the exhaust pipe towards the rear of the vehicle so that the exhaust fumes will naturally move away while the vehicle is in motion.
3. Use standard 2 inch automotive-type exhaust piping and avoid bends if possible. Reference Figure 27.
4. Do not use galvanized pipe or fittings (only black-iron pipe and fittings should be used).

 <p>LDE-200-815</p>	<h2> <b>CAUTION</b></h2> <p><b>Risk of Fire or Equipment Damage</b></p> <p>Hot exhaust tube can ignite flammable materials.</p> <p>Maintain 4-inch/101.6mm clearances from any heat sensitive material, including fuel lines, wiring and hoses.</p>
<p><b>NOTE:</b> Should the particular application require modification of exhaust pipe, please contact the Aqua-Hot Heating Systems Product Application Department at <b>1-800-685-4298</b> for assistance.</p>	

### Installing the Exhaust System

Aqua-Hot separately supplies a kit that contains a 3-inch and 4-inch black pipe nipple (1.5-inch diameter) along with a 1.5-inch exhaust elbow. These three exhaust system components **MUST BE** utilized with all products installations. Be sure to reference Figure 27 to determine which exhaust nipple should be connected directly to the Aqua-Hot's exhaust port (i.e., the 3-inch of the 4-inch black pipe nipple). Also, an exhaust tip is included that must be installed on the end of the exhaust pipe in order to remain in compliance with testing agency. Reference Figure 26.

1. Run the exhaust pipe to the driver's side or the back of the vehicle and ensure that the exhaust fumes cannot enter into the passenger compartment. Be sure to keep the exhaust away from the slide-out areas.
2. Be sure to secure the end of the exhaust pipe to the vehicle with the proper exhaust hanger/support hardware.
3. Slide the exhaust tip (included with the heater) over the end of the exhaust pipe, being sure to leave a required clearance of one inch between the band on the tip and the end of the exhaust pipe. Mark where the holes should be drilled to allow for a #8 sheet-metal screw 3/8 inch in length to securely mount the exhaust tip to the exhaust pipe. Drill the holes in the pipe and mount the exhaust tip. This will prevent excessive air movement up the exhaust pipe, preventing the propane burner from extinguishing. Reference Figure 26.

Figure 24

**CAUTION**

Two black pipe exhaust fittings must be utilized with all installations. Failure to conform could create a hazardous situation and will void the ETL listing of the Aqua-Hot unit.

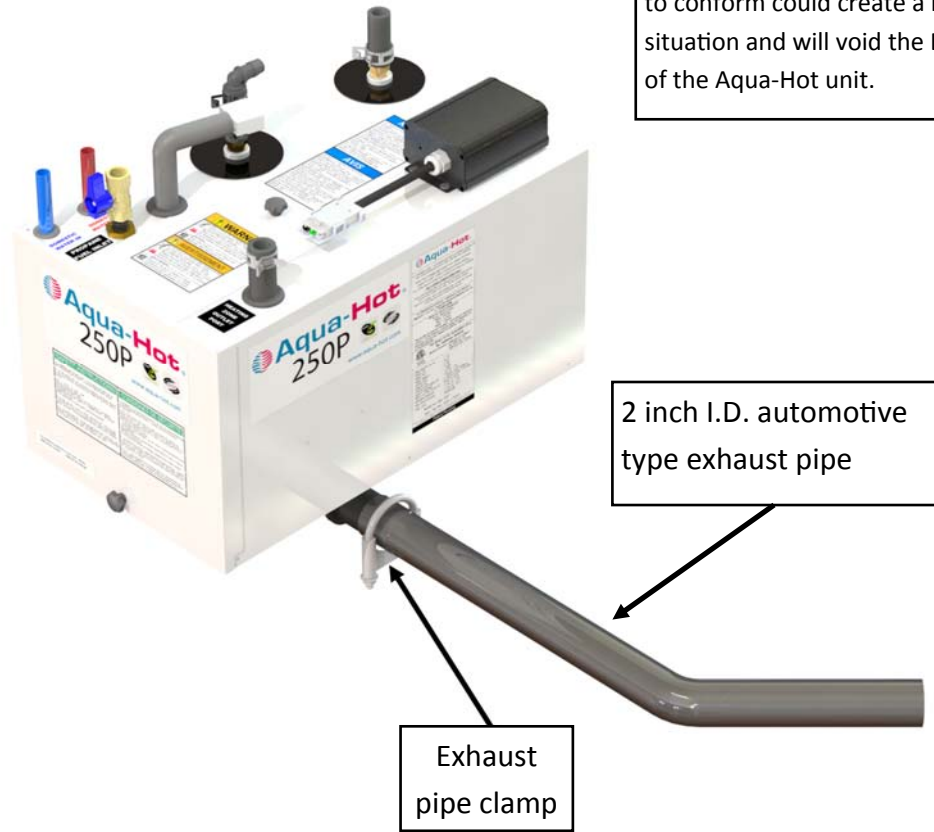
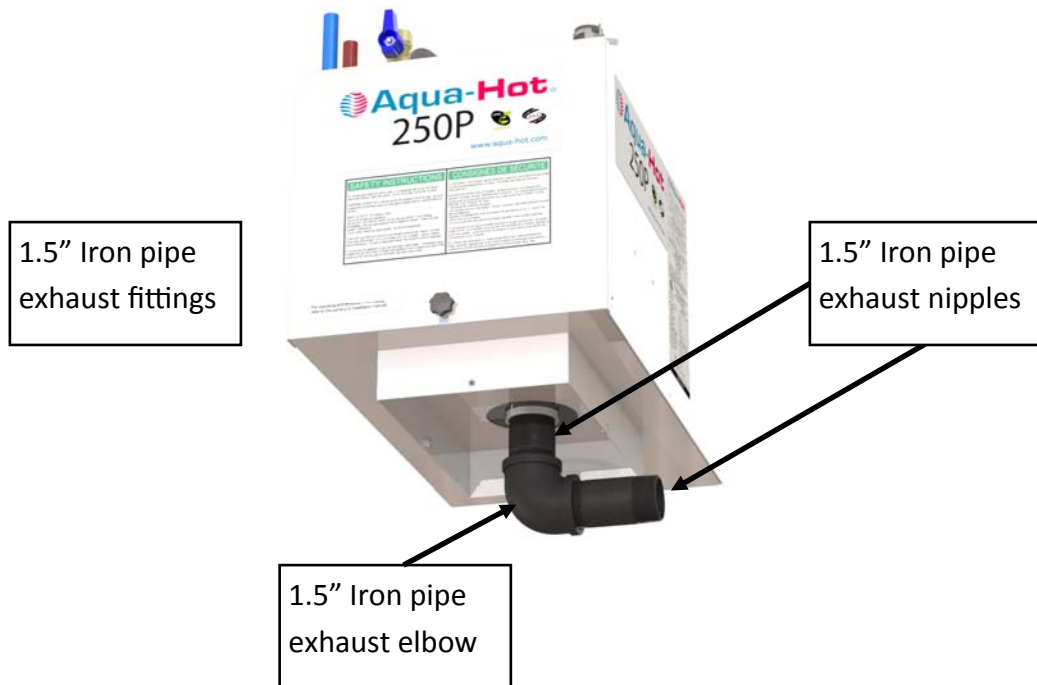

Figure 25







**WARNING**

**Heater Exhaust Produces Carbon Monoxide (CO<sub>2</sub>)**

Carbon Monoxide (CO<sub>2</sub>) can cause headaches, brain damage or death. **DO NOT** operate heater within a closed interior area. Confirm heater switch is in OFF position when vehicle is in an enclosed space.

LDE-200-805

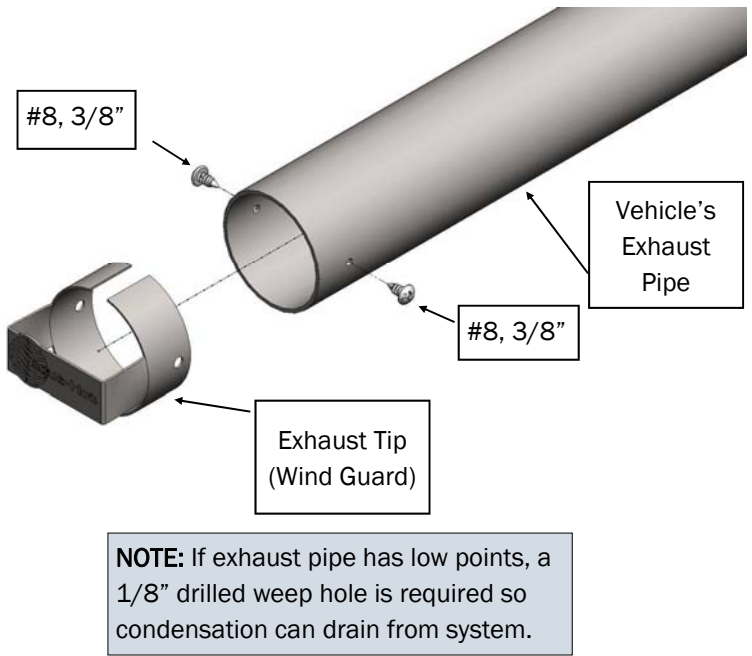
Figure 26

**CAUTION**

**Risk of Fire or Equipment Damage**

Hot exhaust tube can ignite flammable materials.

Maintain 4-inch/101.6mm clearances from any heat sensitive material, including fuel lines, wiring and hoses.

LDE-200-815

Figure 27

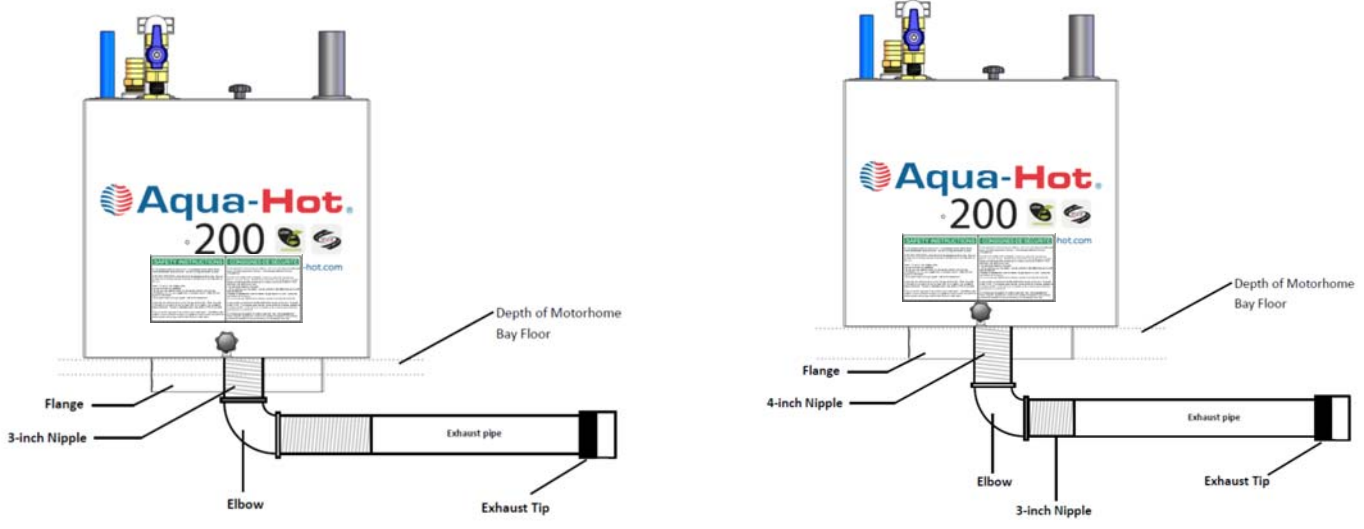

**NOTE:** Exhaust Termination must be at least 3 ft from any coach openings (e.g. doors/ windows)

## Connecting the 12 Volt-DC Power

### CAUTION

DO NOT connect the 12 Volt-DC power to the Aqua-Hot if the vehicle requires welding. Electrical welding will cause serious damage to the propane-burner controller.

Before connecting power to the Aqua-Hot, it is imperative that the proper wire gauge be determined and utilized. Reference ANSI/RVIA-LV for proper wire-gauge sizing. Please note that under full-load conditions, the Aqua-Hot can draw as much as 10 amps of DC current.

Be sure to protect against accidental shorting (i.e., chassis shorting) by incorporating a 10-Amp rated in-line fuse into the power wire at the battery location. The following table calls out the proper connector and terminals needed to interface with the Aqua-Hot:

Table 1: Eight-way female connector and terminals		
Connector/ Terminal	Manufacturer Part Number	Image of Part
TE Connectivity 8 Way Fastin Receptacle Housing	163007	
TE Connectivity <b>12-16 AWG</b> 0.25 Fastin Receptacle	60253-2	
TE Connectivity <b>14-18 AWG</b> 0.25 Fastin Receptacle	42100-2	

1. Run two, properly gauged, wires (colored red for + and black for – ) from the main power disconnect to the eight-way pin connector located on the top of the Aqua-Hot. The + red power wire must be fused with a max “25” amp fuse to protect the Aqua-Hot heater from overcurrent.
2. Crimp the appropriate terminals called out in from Table 1 to the wires. Perform a pull test to ensure that the wires do not come out of the terminals. Insert the power wire power (+) to Pin #1 of the eight-way receptacle housing connector. Insert the ground wire (–) to Pin #2 of the eight-way receptacle housing connector.

## Wiring the Coach Thermostat to the Eight-Way Pin Connector

1. Run two, properly gauged, wires (colored red for + and black for – ) from the coach room thermostat to the eight-way pin connector located on the top of the Aqua-Hot.
2. Crimp the appropriate terminals called out in from Table 1 to the wires. Perform a pull test to ensure that the wires do not come out of the terminals. Insert the positive signal wire from the thermostat to Pin #5 of the eight-way receptacle housing connector. Insert the thermostat ground wire to Pin #6 of the eight-way receptacle housing connector.

**NOTE:** For wiring cozy heat exchangers, reference page 20

### Connecting the 120 Volt AC Power

**NOTE:** A 15 Amp sized fuse panel breaker is required.

## **WARNING**

*DO NOT activate the propane-burner until the antifreeze and the water heating solution has been added to the boiler tank and the heating system has been completely bled of air. Operating the Aqua-Hot without the antifreeze and the water heating solution will cause serious damage to the Aqua-Hot's boiler tank.*

1. Route three 120 VAC power source wires to the Aqua-Hot heater.
2. Using the Molex connector called out below, crimp the 120 VAC power source wire into connector.
3. Plug the 120 VAC connector into the mating connector of the Aqua-Hot heater.

Figure 28

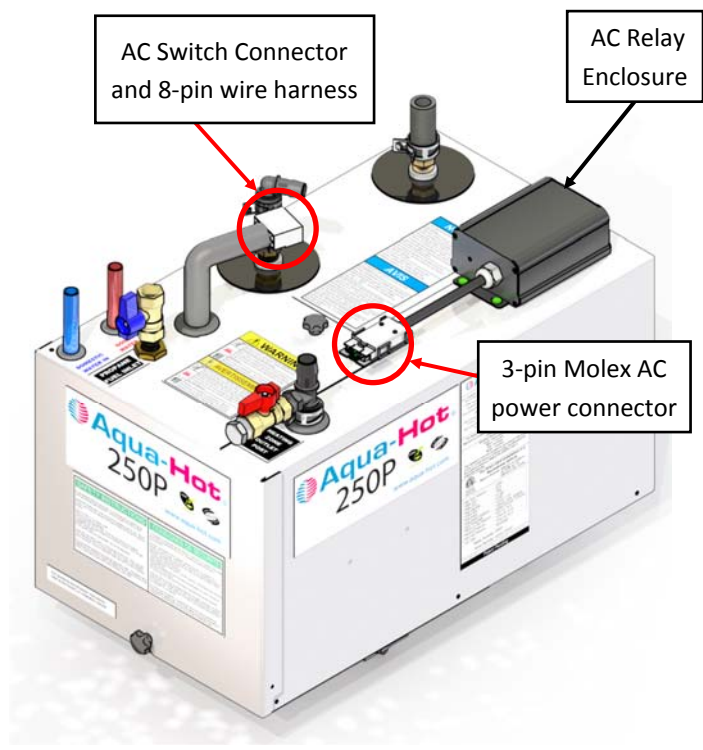

Two-pin AC Control Switch Connector		
Connector/ Terminal	Manufacturer Part Number	Image of Part
TE Connectivity AMP Connector, Fastin-Faston Series	180908	

Any of the below Molex Connectors may be used for 3-pin AC Power:

**Self-Contained Power Connector – 2-circuit for Solid Wire**

Wire Range	Part Number	Housing Color
12AWG-14AWG	19045-1000	White

**Self-Contained Power Connector – 2-circuit for Stranded Wire**

Wire Range	Part Number	Housing Color
14AWG-16AWG	19403-1011	Blue
12AWG	19403-1010	Yellow



## Purging the Hydronic Heating System

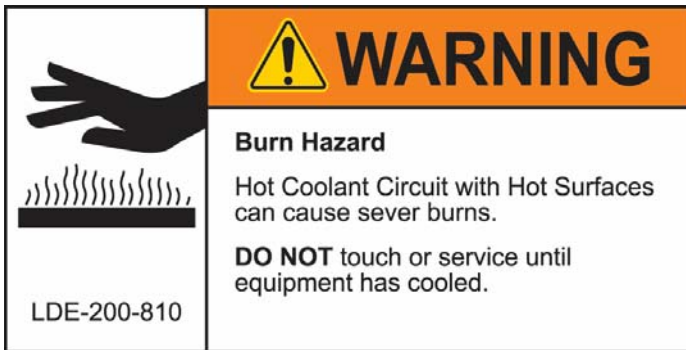

In order to provide the best freeze protection, boil-over protection, and anti-corrosion and rust protection, a 50/50 mixture of “GRAS” approved propylene glycol antifreeze and water is recommended.

Be sure to use a “GRAS” boiler-type propylene glycol based antifreeze rather than an RV and Marine antifreeze or an automotive antifreeze/coolant.

If assistance is needed in selecting an appropriate antifreeze, please contact the Aqua-Hot Heating Systems Product Application Department at 1-800-685-4298.

**NOTE:** The Aqua-Hot has a 3-way coolant directional valve to control coolant priority, therefore the system *must* be filled as described below.

1. Find the purge valve of the Aqua-Hot located top of the zone port outlet. Reference Fig. 29.
2. Make a 1/2” NPT connection from the propylene glycol source to the purge valve (see Fig. 29).
3. Make a 5/8” hose barb connection from the expansion bottle port to the return of the propylene glycol source.
4. Start the fluid transfer pump of the propylene glycol source and begin filling the Aqua-Hot with 50/50 mixture of antifreeze and water heating solution. Monitor the return line and stop filling once there are no air bubbles and/or foam in the line.
5. Remove the return line from the expansion tank port.
6. Install the expansion hose line and bottle.
7. Begin filling the Aqua-Hot until the coolant reaches the “Cold” line designated on the expansion tank.
8. Turn off the fluid transfer pump and close the purge valve.
9. Disconnect the fill line from the purge valve.



Only propylene glycol based “boiler” type antifreeze deemed “GRAS” (Generally Recognized as Safe) by the FDA shall be used in the Aqua-Hot’s hydronic heating System. Failure to use the above specified antifreeze type could result in serious injury or death.



Ensure that the overflow tube is connected from the Aqua-Hot’s expansion tank connection to the expansion tank’s bottom connection. Also, from the expansion tank’s top connection through the overflow tube hole in the motor home’s bay floor prior to beginning this antifreeze and water heating solution fill procedure. Failure to do so could result in an antifreeze spill in the motor home’s bay. Reference Figure 4.

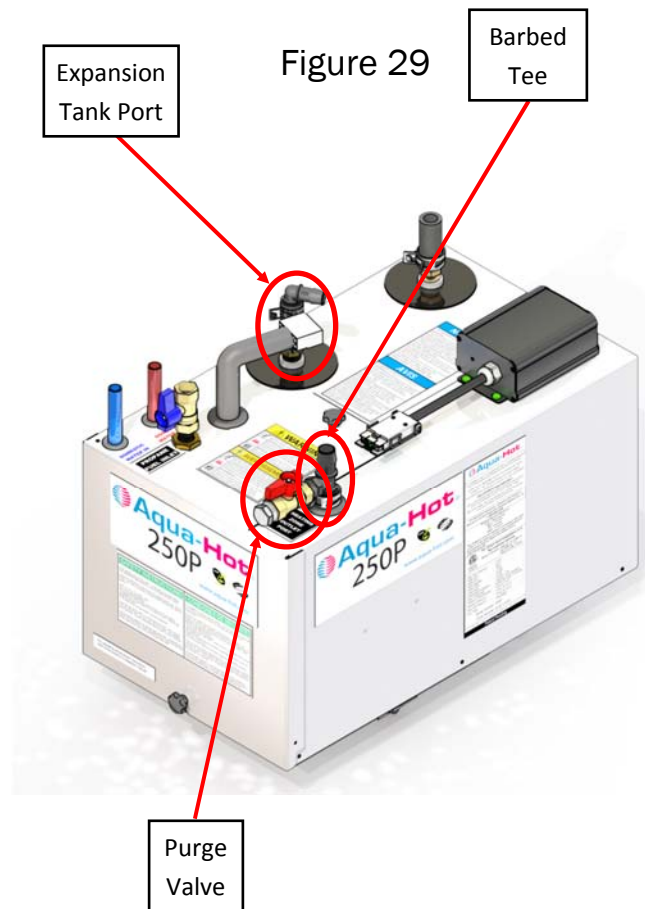

## Activating the Aqua-Hot

**NOTE:** The propane burner may not light on the first attempt if air is still present in the line. It will attempt to light automatically three times and once the propane is present, it will light successfully. The first light may be noisy, but the second light should be purged and stable.

**NOTE:** The main access cover must be installed prior to operation. A safety switch exists, which will prevent the Aqua-Hot from operating whenever the main access cover is not properly installed.

1. Move the Aqua-Hot's electric element switch to the ON position in order to supply 120 Volt-AC power to the electric heating element (250P models only).
2. Allow approximately 30 minutes for the Aqua-Hot to heat the tank. Turn on any coach hot water tap to verify that the electric is heating tank. (It will take between 1-2 hours for the electric element to bring the tank completely up to operating temperature. )
3. Move the burner switch to the ON position and leave it on in order to activate the burner.

**NOTE:** It will take approximately 15 seconds before the burner will ignite and exhaust can be heard exiting the heater.

**NOTE:** Both the 12 Volt-DC powered burner and the electric heating element are thermostatically controlled. Either or both heating sources will automatically maintain the temperature of the boiler tank's antifreeze and water heating solution.

## Interior Heat

1. Turn room thermostat to a warmer temperature to activate heating zone.

**NOTE:** Heating zone will operate once the tank is heated and no domestic water flow is present.



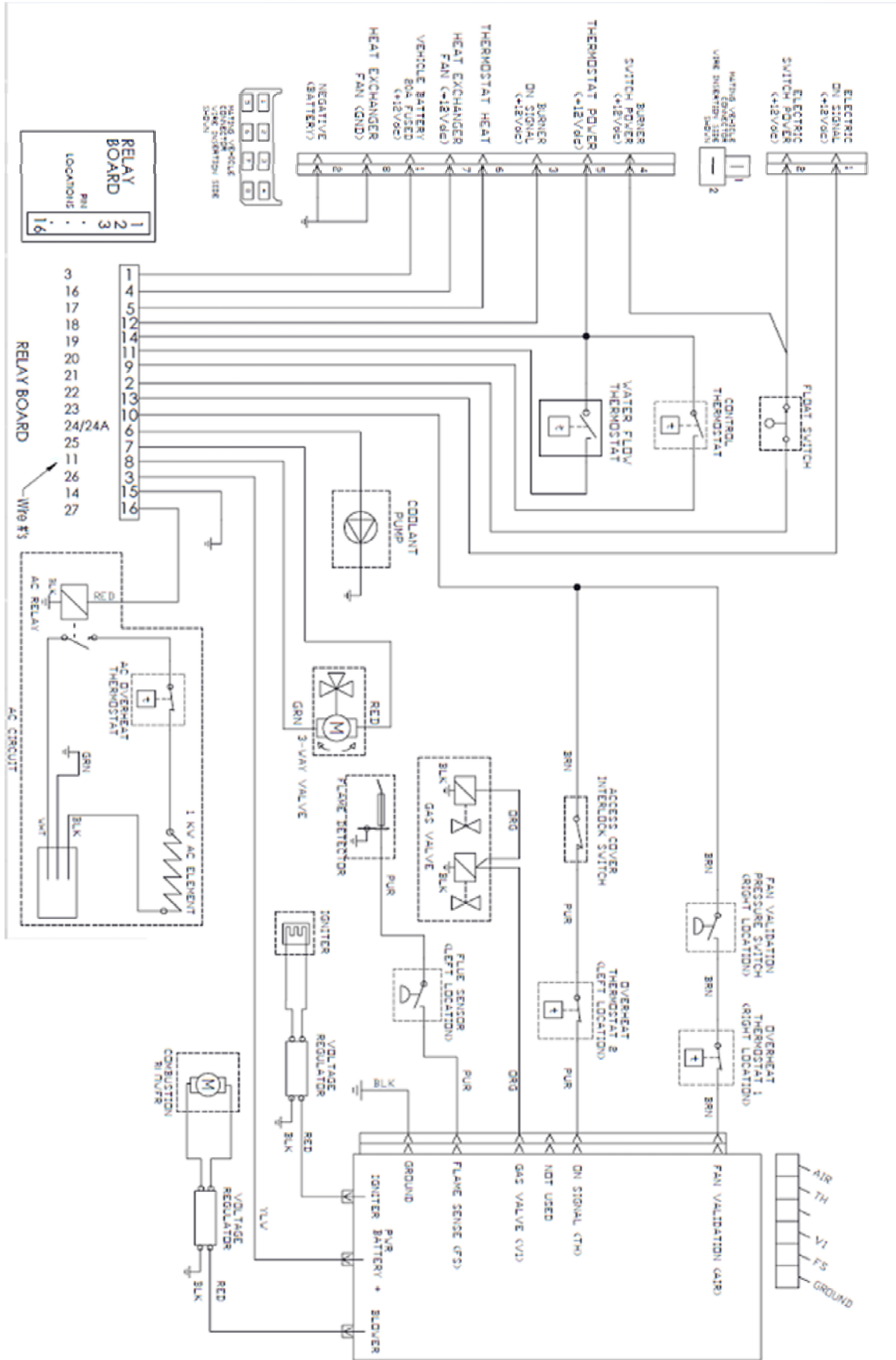



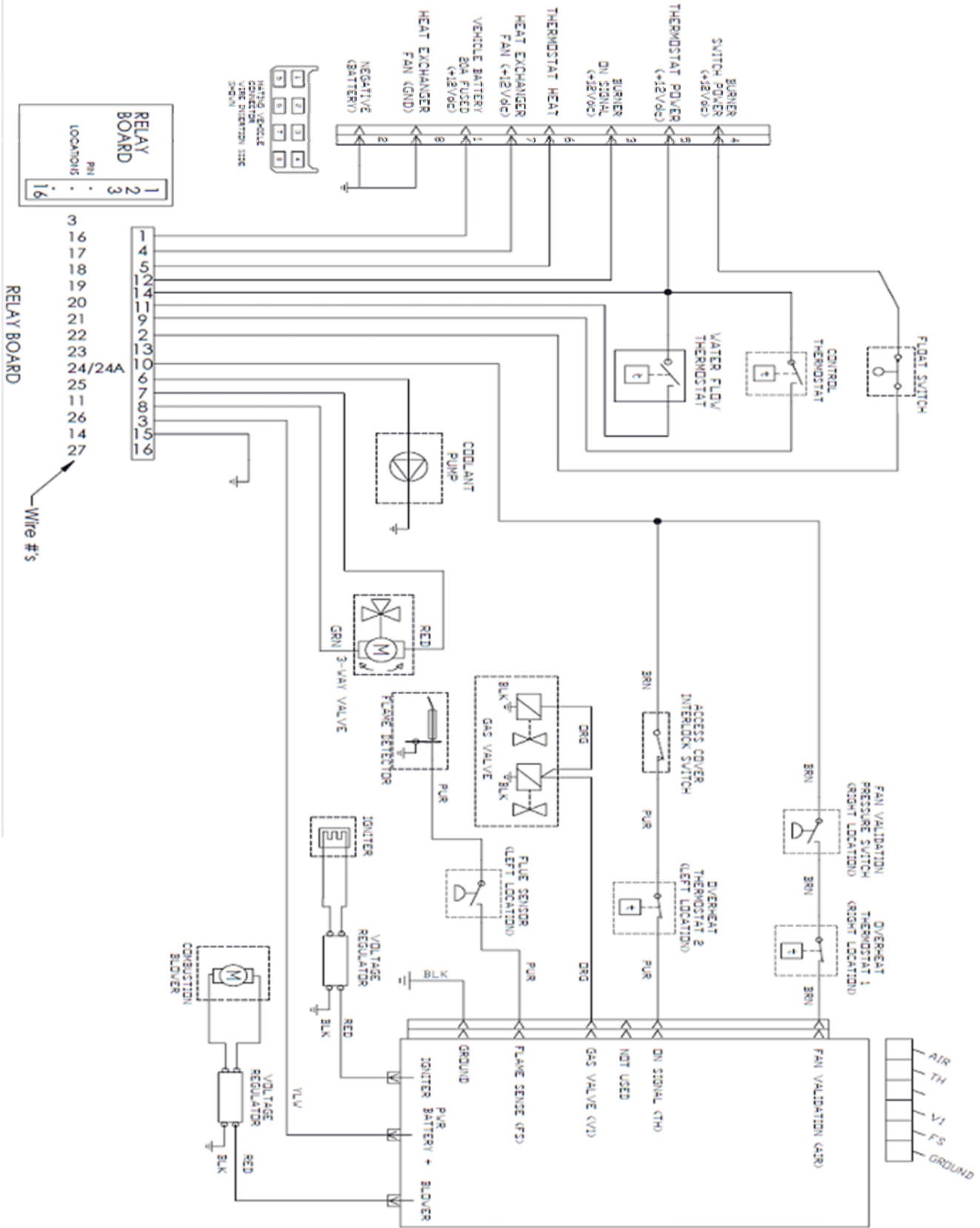

## Using the Refractometer to Test Antifreeze Sample

### Basic Operation

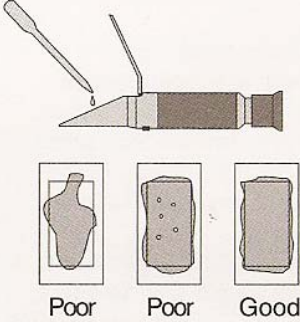
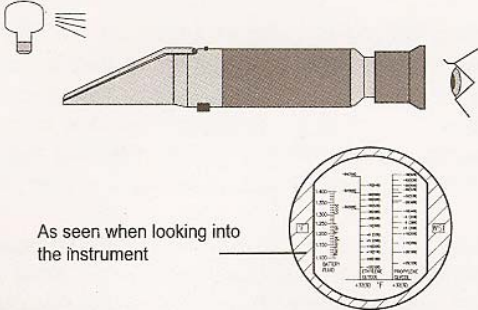
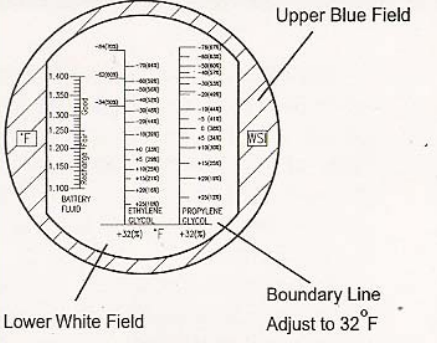
 <p>Poor      Poor      Good</p>	 <p>As seen when looking into the instrument</p>	 <p>Upper Blue Field</p> <p>Lower White Field</p> <p>Boundary Line Adjust to 32°F</p>
<p><b>Step 1:</b></p> <p>Open daylight plate, and place 2 to 3 drops of the sample on the main prism. Close the daylight plate so the liquid sample spreads across the entire surface of the prism without air bubble or dry spots. Allow the sample to rest on the prism for approximately 30 seconds before going to step 2. (This allows the sample to adjust to the ambient temperature of the refractometer).</p>	<p><b>Step 2:</b></p> <p>Hold daylight plate in the direction of a light source and look into the eye piece. You will see a circular field with graduations down the center (you may have to focus the eye-piece to clearly see the graduations). The upper portion of the field should be blue, while the lower portion should be white.</p>	<p><b>Step 3:</b></p> <p>Take the reading where the boundary line of the blue and white cross the graduate scale. The scale will provide a reading of the freezing point of anti-freeze solution and the propylene glycol concentration. Clean the prism carefully using a damp soft cloth. Do NOT immerse in water.</p>

# 200<sub>SERIES</sub>

## 2-YEAR LIMITED WARRANTY AQUA-HOT® HYDRONIC HEATING SYSTEM

### 200P or 250P

Aqua-Hot Heating Systems Inc. warrants the Aqua-Hot Heater to be free from defects in material and workmanship under normal use and service for a period of two years on both parts and labor commencing upon the original date of registration of the vehicle. Replacement parts are warranted for the remainder of the Heater's standard warranty coverage or for six months, whichever is greater. The intent of this warranty is to protect the Heater's end-user from such defects, which would occur in the manufacturing of the product. Thus, problems due to improper specifications, improper installations, improper use, the use of accessory parts or parts not authorized by Aqua-Hot Heating Systems Inc., repair by unauthorized persons, and damage or abuse of the heater are specially excluded from warranty coverage.

For additional information or to obtain a warranty repair authorization, please contact the *Aqua-Hot Heating Systems Warranty Administrator at 1-800-685-4298 (8:00 AM to 5:00 PM Mountain Standard Time) or visit [www.aquahot.com](http://www.aquahot.com).*

### **My Comfort Zones are On-Board**

Vehicle:

### **Purchased From:**

Dealer Information:

Name:

Location:

Phone Number:

### **Heating System:**

Serial Number:

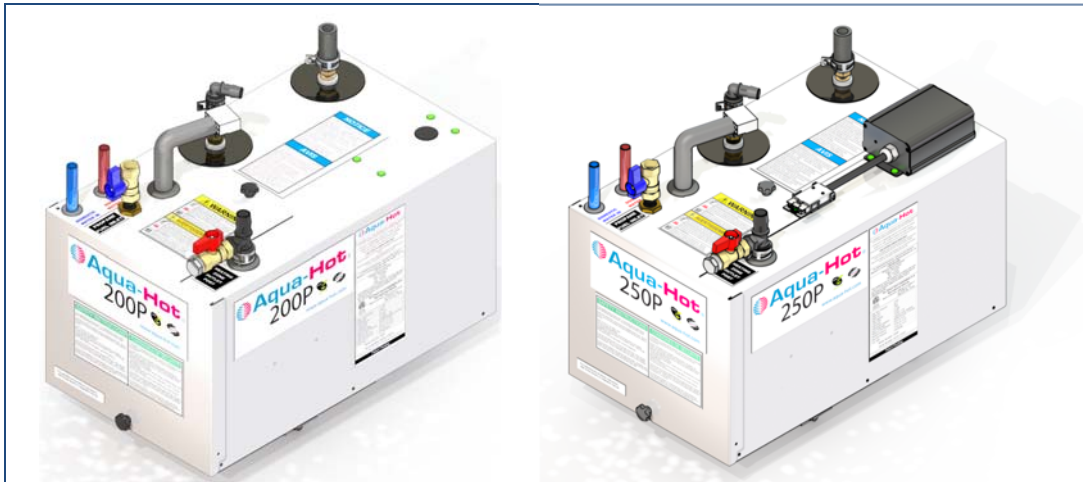

AHE-200-P01  
Heater, Hydronic 60K BTU 12VDC

AHE-250-P01  
Heater, Hydronic 63.4K BTU 12VDC  
1KW Electric Element



Panel, Switch 1-Position ASM



ELE-000-508  
Panel, Switch 2-Position ASM (250p only)



EXE-103-0EX  
Exchanger, Heat Cozy III



PLE-063-200  
Overflow bottle Kit (Tank, CONS hose, clamp, CONS tie, labels)

	
<p>MSE-200-EXH Exhaust Kit (1.5" x 3", 1.5" x 4" nipple fittings, 1.5" x 1.5" elbow fitting, label)</p>	<p>EXX-013-100 Nozzle, Round 4" w/o Connector, Black</p>
	
<p>PLX-CTB-270 Clamp, Hose Constant Tension, 0.75"</p>	<p>SME-102-000 Plenum, Assembly, Cozy</p>
	
<p>PLX-T44-006 Fitting, Insert Modified Brass</p>	<p>PLX-284-74V Hose, Molded, Elbow 90deg, .75" x .75" x 10" Long</p>
	
<p>EXX-D16-200 Heat Exchanger, Komfort Defroster 12VDC</p>	<p>ELX-500-510 Thermostat, Low Temp 019-063 Assembly</p>

	
<p>ELX-700-007 Thermostat, Room, Positive Off</p>	<p>EXX-950-411 Grille, 10" x 2" Cozy</p>
	
<p>EXX-006-500 Grille, Long, 3.5" x 21.5", Black</p>	<p>EXX-006-501 Grille, Medium, 3.5" x 15", Black</p>
	
<p>EXX-006-502 Grille, Small, 3.5" x 8.5", Black</p>	<p>PLX-000-443 Tube, 5/8", Safety Stripe, 12 ft.</p>
	
<p>PLX-A51-106 Bend Supports, 5/8"</p>	<p>PLX-284-74V Hose, Molded, Elbow 90°, .75" x .75" x 10"</p>



	
<p>PLX-A65-200 Fitting, Brass, Barb, .75" x .5" (M)NPT</p>	<p>PLX-A65-300 Fitting, Brass, Barb 90°, .75" x .5" (M)NPT</p>
	
<p>PLX-000-820 Fitting, Elbow, .75", Barb Black Nylon</p>	<p>PLX-200-103 Fitting 1/2(M)NPT by 3/4 Barb Black Nylon</p>
	
<p>PLX-000-835 Fitting, Reducer 3/4" to 5/8" Black Nylon</p>	<p>PLX-432-000 Fitting, Straight 1/2 Pex x 1/2 (M) NPT PSF</p>
	
<p>PLX-803-000 Fitting, Straight, 1/2 PEX by 1/2 (F)NPT</p>	<p>PLX-100-836 Pump Mounting Bracket</p>

	
<p>PLX-803-ELB Elbow Fitting, 90°, 1/2" PEX x 1/2" PSF</p>	<p>PLX-803-FSE Elbow Fitting, 90°, 1/2" PEX Fitting</p>
	
<p>EXE-505-65A Heat Exchanger, Whisper Silent 12 VDC</p>	<p>PLX-664-730 Fitting, Pipe Nipple, Exhaust, 1-1/2" x 4"</p>
	
<p>PLX-664-750 Fitting, Exhaust, Nipple 1-1/2" x 3" NPT</p>	<p>EXX-013-105 Nozzle, Round 4" w/ 2-1/2" Connector, Black</p>
	
<p>SME-375-015 Tip, Exhaust End</p>	<p>MSX-300-300 1 gallon green boiler antifreeze</p>



	
<p>MSX-300-270 1 Gallon Pink Boiler Antifreeze</p>	<p>MSX-300-275 Propylene Glycol Concentrate, Pink</p>
	
<p>PLX-100-900 Boost Pump with Harness</p>	<p>ELE-400-900 Boost Pump Harness</p>



INSTALLATION MANUAL

# 200 SERIES



200P and 250P



Aqua-Hot Heating Systems, Inc.

7501 Miller Drive, Frederick, CO 80504

Visit us on line at [www.aquahot.com](http://www.aquahot.com)

Call us at (800) 685-4298 or (303) 651-5500